



## TEMARIO AULA

---

### **Tema I** INTRODUCCIÓN A LA MAQUINA ELECTRICA

- I.1.- Fundamentos electromagnéticos y electromecánicos
- I.2.- Consideraciones previas sobre las máquinas eléctrica

### **Tema II** TRANSFORMADORES

- II.1.- Introducción a los transformadores
- II.2.- Transformadores monofásicos de potencia
- II.3.- Transformadores trifásicos. Régimen equilibrado
- II.4.- Autotransformador

### **Tema III** GENERALIDADES SOBRE MAQUINAS ELECTRICAS ROTATIVAS

---

- III.1.- Máquina eléctrica rotativa. Aspectos constructivos
- III.2.- FMM en el entrehierro y FEM inducida en la MR

### **Tema VI** MAQUINA ASINCRONA. REGIMEN EQUILIBRADO

- IV.1.- La máquina asíncrona trifásica
- IV.2.- Comportamiento de la máquina asíncrona trifásica
- IV.3.- Motor de inducción monofásico

### **Tema VII** MAQUINA SINCRONA

### **Tema VIII** MAQUINA DE CORRIENTE CONTINUA



### *Tema III GENERALIDADES SOBRE MAQUINAS ELECTRICAS ROTATIVAS*

*III.1.- Máquina eléctrica rotativa. Aspectos constructivos*

*III.2.- FMM en el entrehierro y FEM inducida en la MR*



### III.2.- FMM en el entrehierro y FEM inducida en la MR

FMM inducido (i)

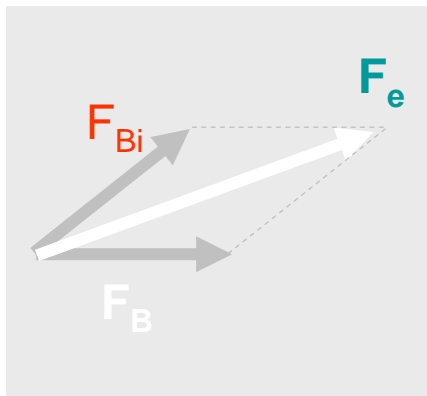

FMM entrehierro

FMM inductor (B)

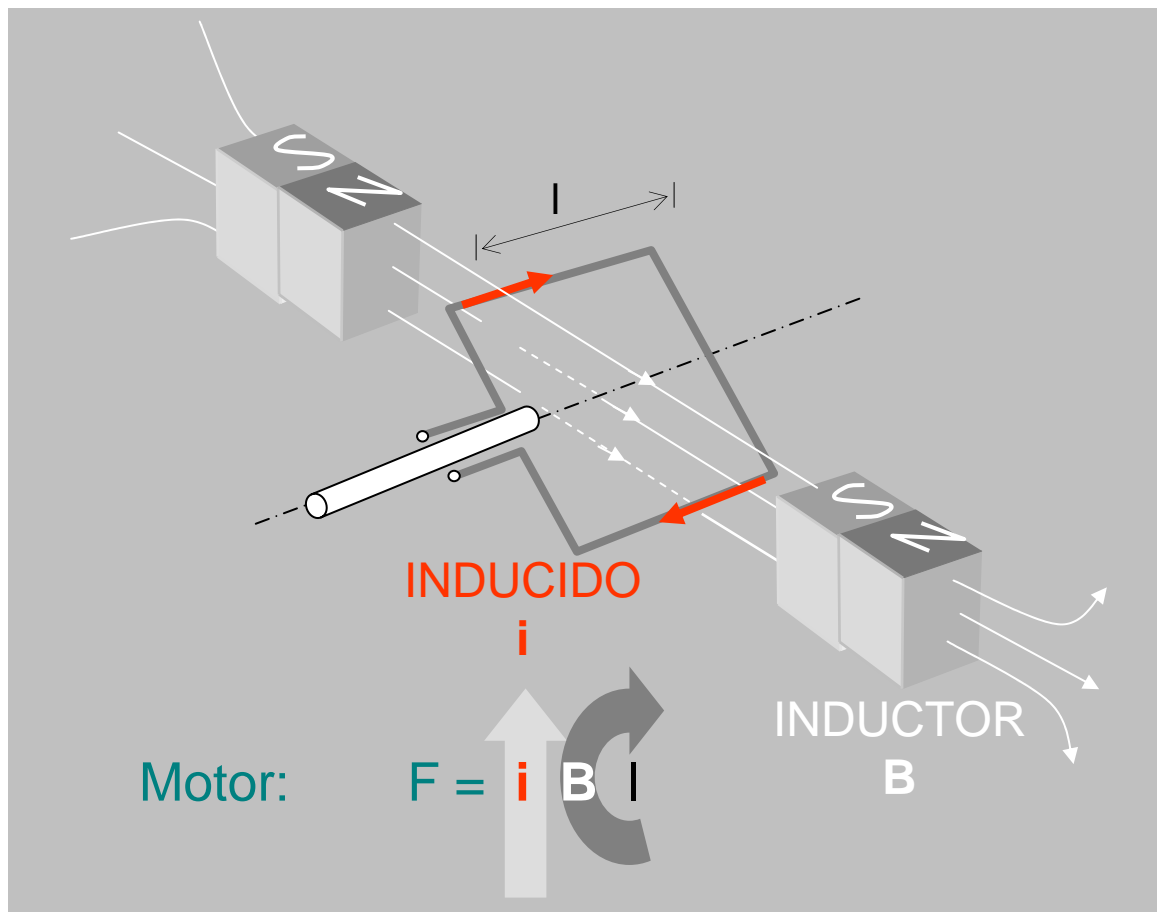
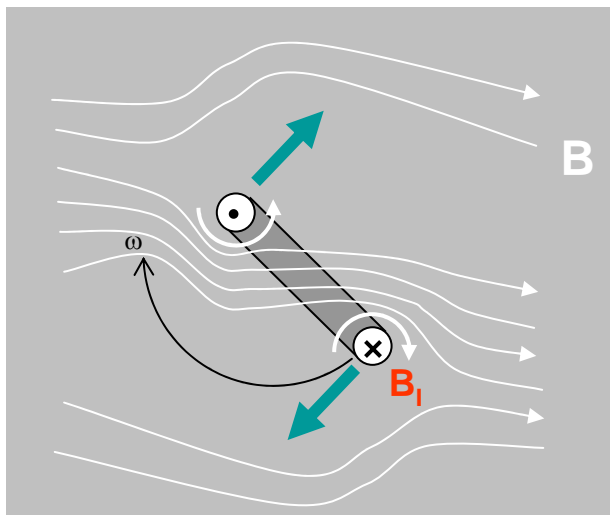



### III.2.- FMM en el entrehierro y FEM inducida en la MR

FMM inducido (i)

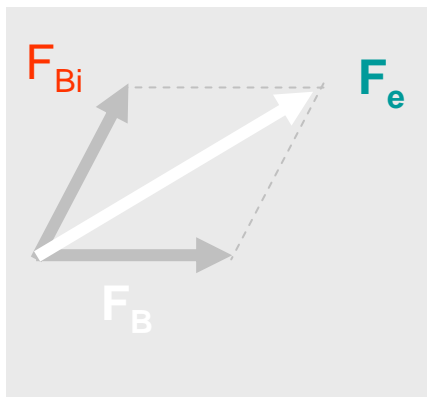

FMM entrehierro

FMM inductor (B)

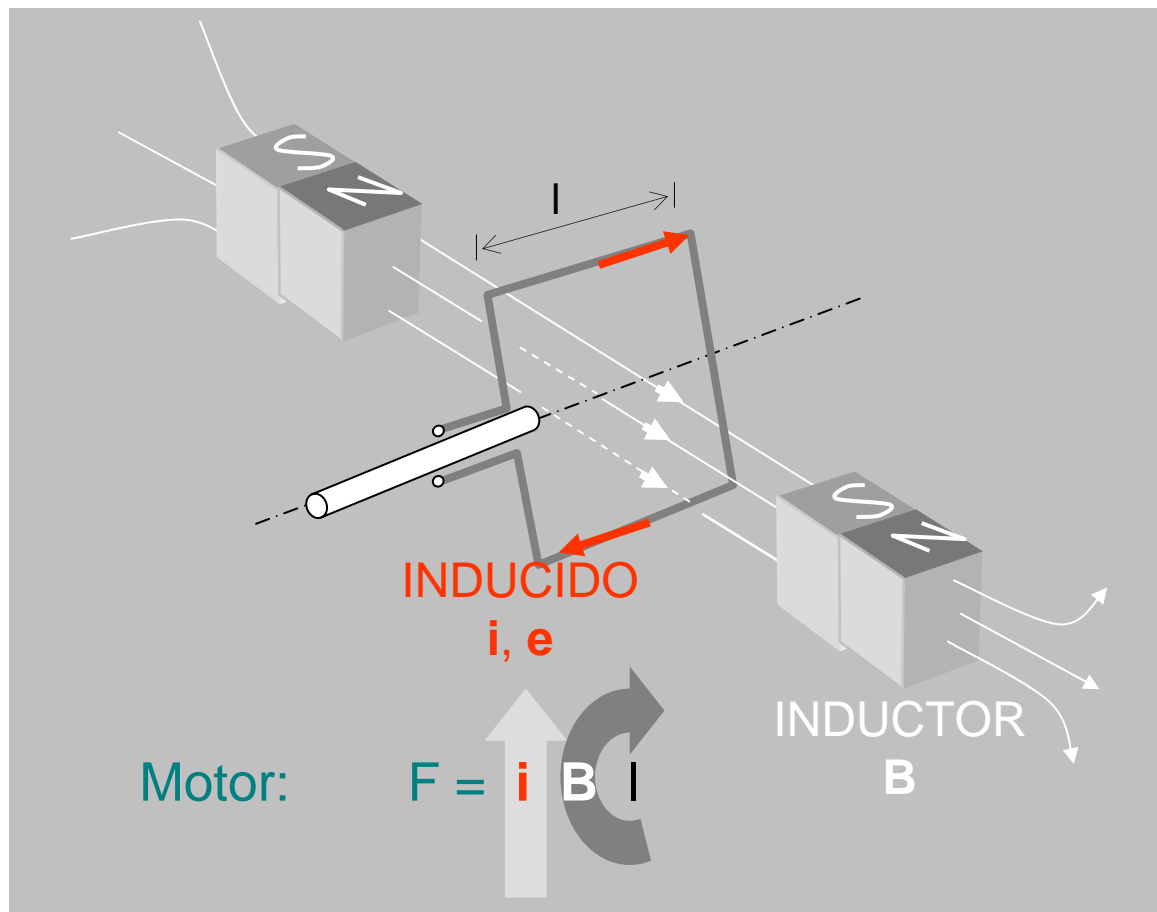
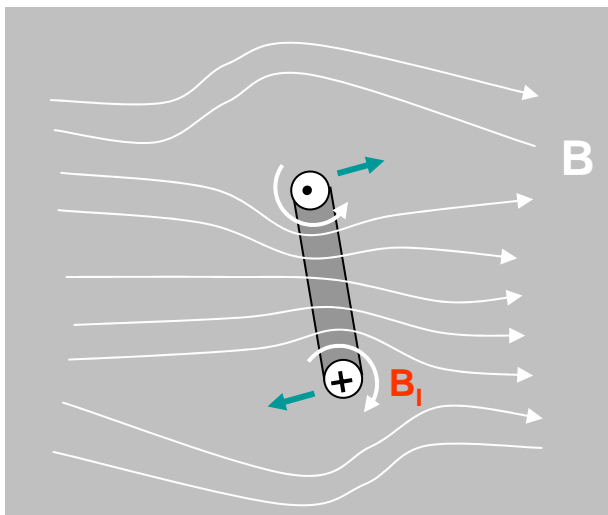



FMM inducido (i)

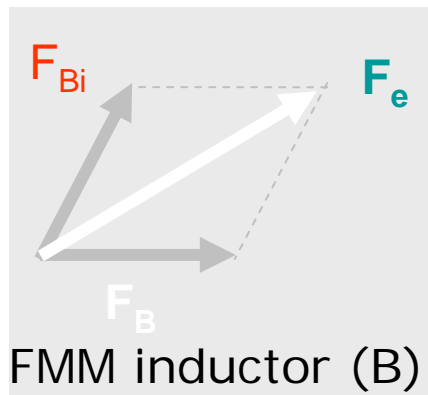

FMM entrehierro

### OBJETIVO

1. Estudio de las formas de onda de las FMM
2. Estudio de la FEM en el inducido en la M.E.R.  
Dependiendo del devanado (concentrado/distribuido)

Hipótesis:

- entrehierro uniforme (estator y rotor cilindricos).
- permeabilidad del hierro infinita, frente a la del aire en el entrehierro.
- máquina bipolar (dos polos,  $2p=2$ ).



## **FMM en el entrehierro**

### **DEVANADO CONCENTRADO DE PASO DIAMETRAL**

Alimentación C.C. (Campo fijo)

Alimentación C.A. (Campo pulsante)

### **DEVANADO DISTRIBUIDO DE PASO DIAMETRAL**

### **CAMPO GIRATORIO**

Teorema de Ferraris

Teorema de Leblanc

### **FEM INDUCIDA EN EL DEVANADO DE LA M.E.**



## FMM en el entrehierro

### DEVANADO CONCENTRADO DE PASO DIAMETRAL

Tipo de alimentación:

Alimentación C.C. (Campo fijo)

Alimentación C.A. (Campo pulsante)

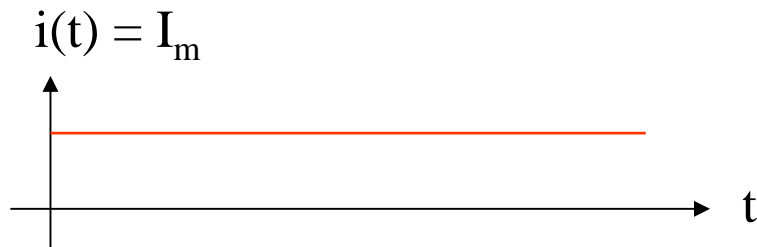

Alimentación C.C. (Campo fijo)

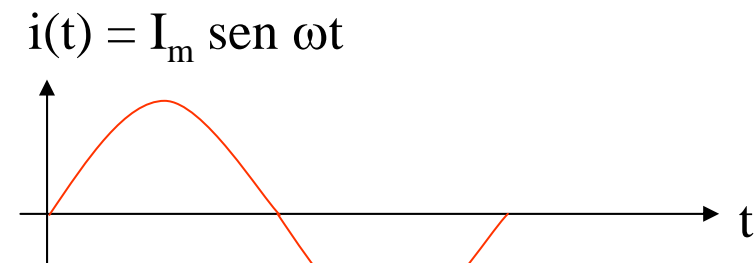

Alimentación C.A. (Campo pulsante)



## FMM en el entrehierro

### DEVANADO CONCENTRADO DE PASO DIAMETRAL

Alimentación C.C. (Campo fijo)

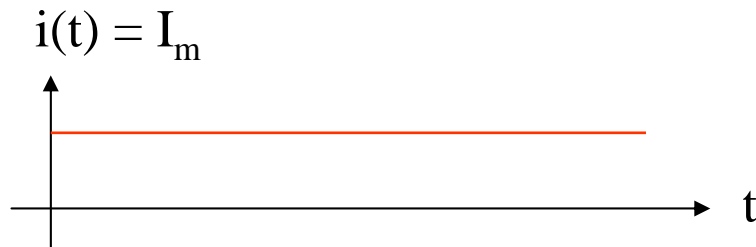

Alimentación C.C. (Campo fijo)



**FMM en el entrehierro. DEVANADO CONCENTRADO DE PASO DIAMETRAL**

Alimentación C.C. (Campo fijo)

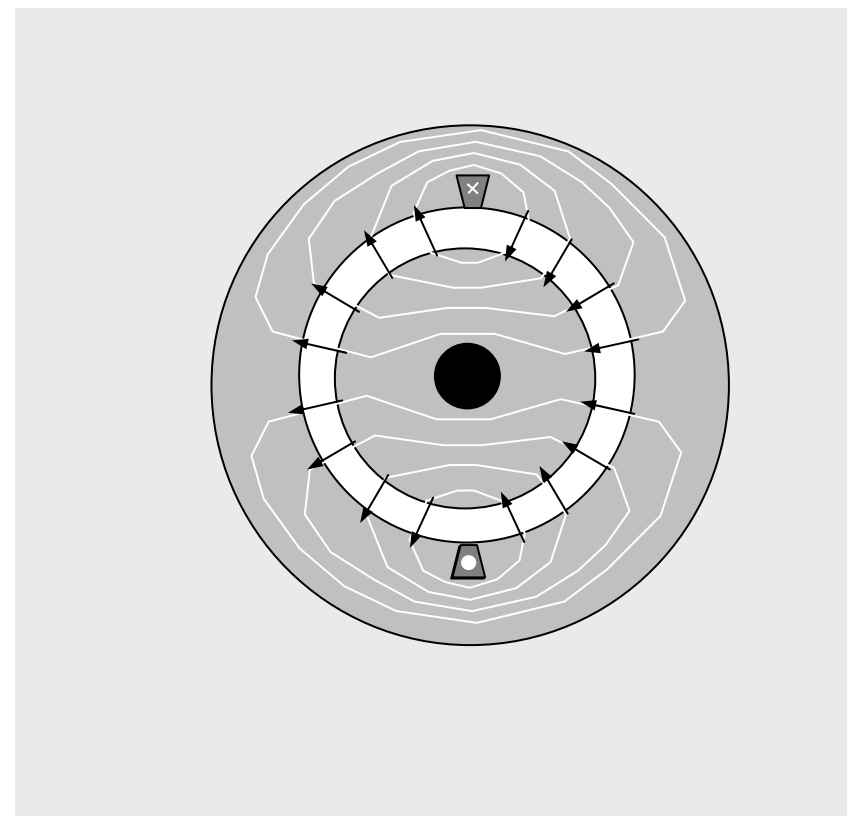
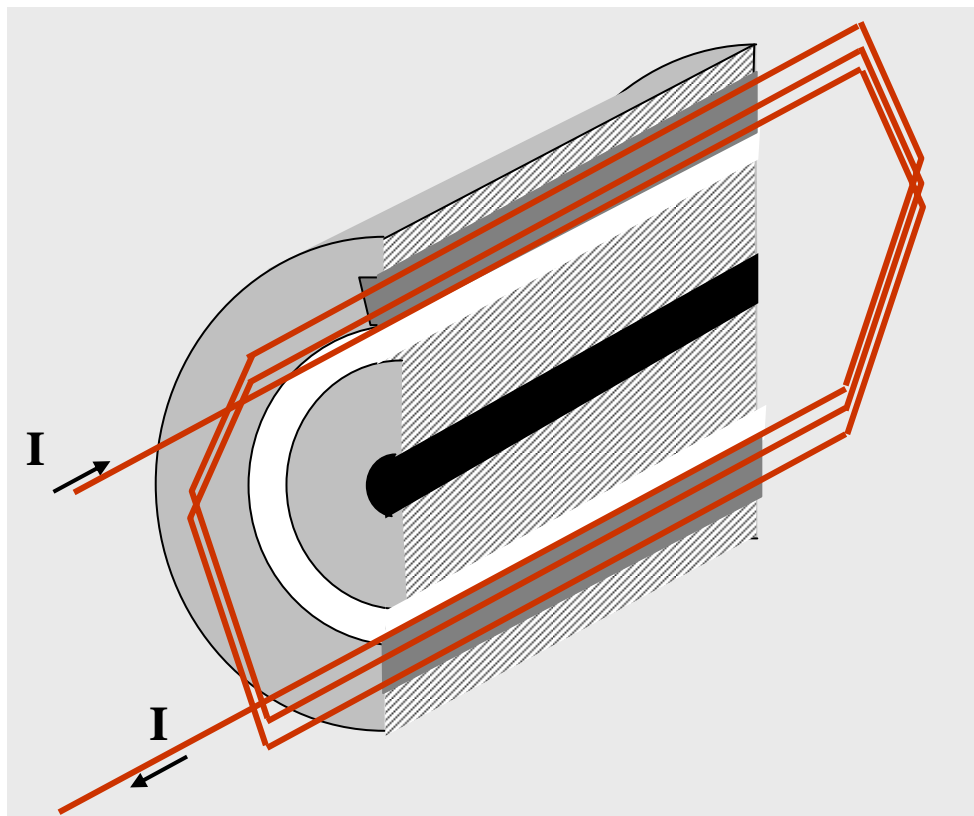



FMM en el entrehierro. DEVANADO CONCENTRADO DE PASO DIAMETRAL

Alimentación C.C. (Campo fijo)

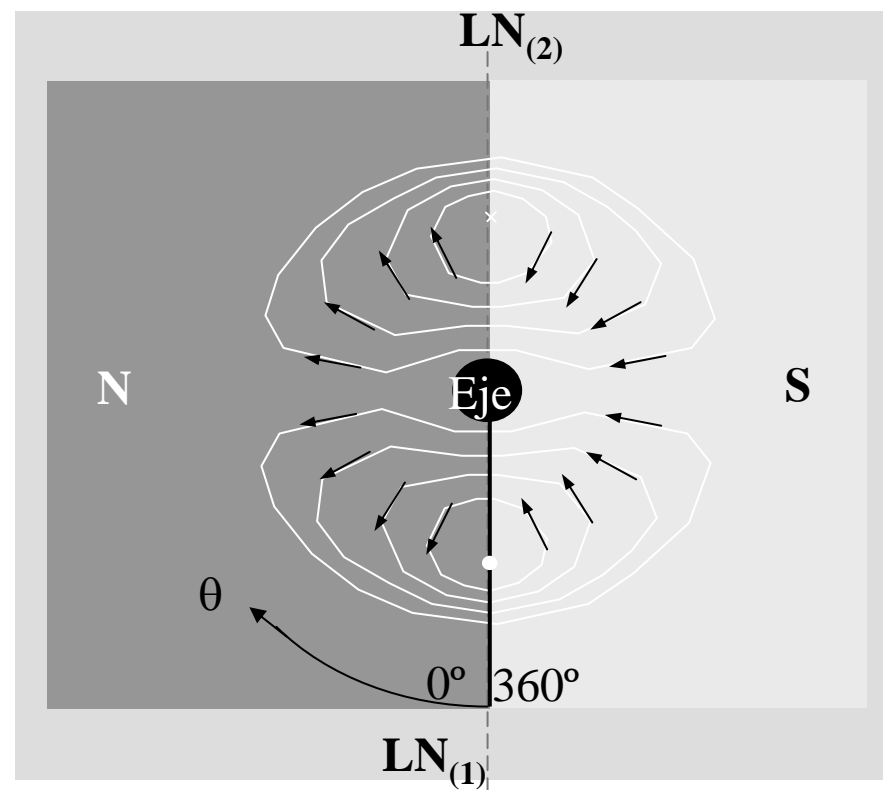
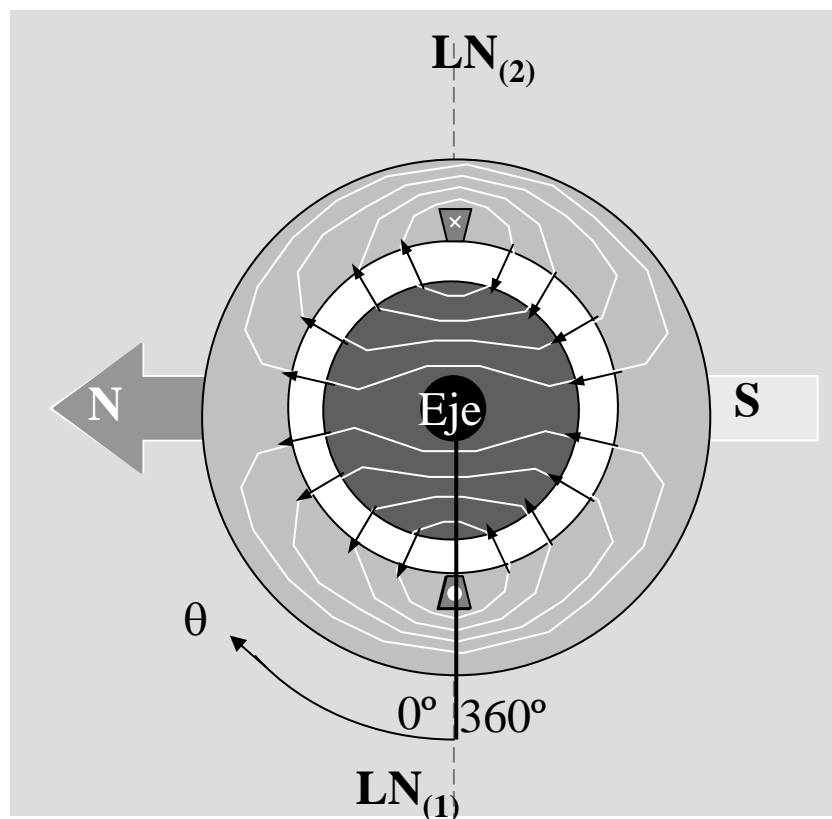



FMM en el entrehierro. DEVANADO CONCENTRADO DE PASO DIAMETRAL

Alimentación C.C. (Campo fijo)

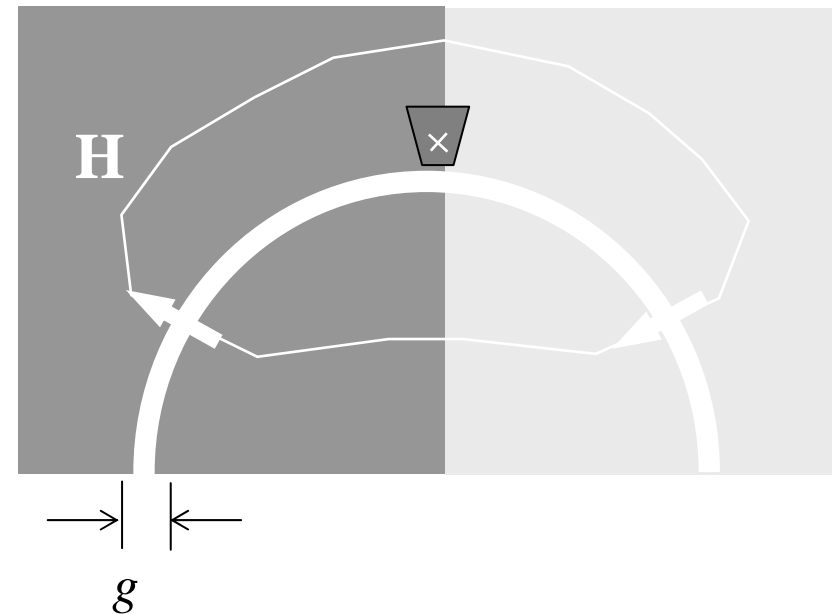
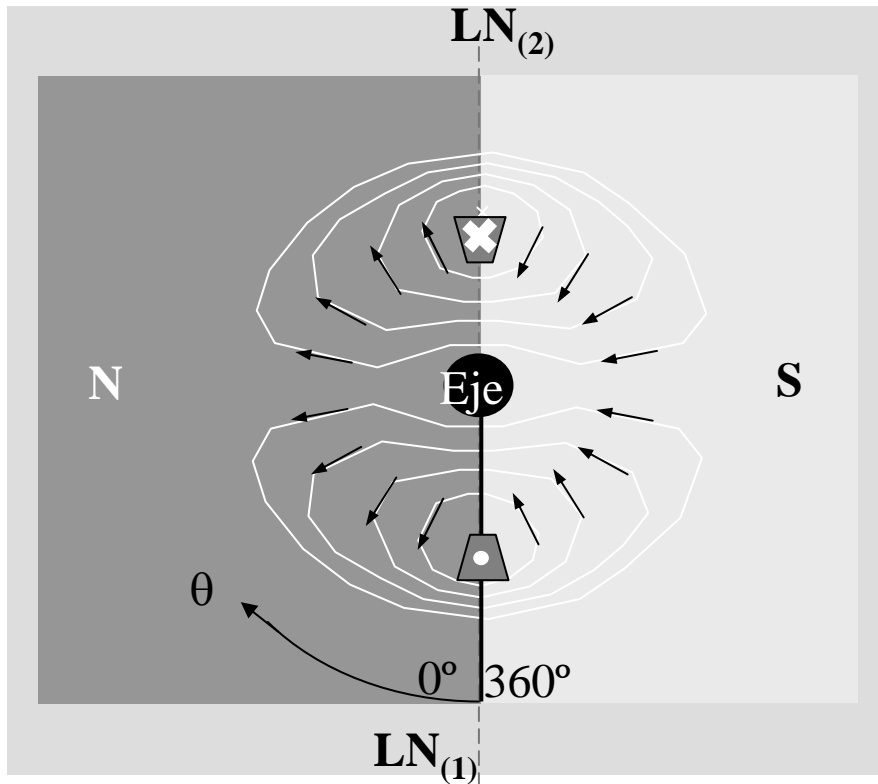

$$2 F_m = N I = H 2g$$

$$F_m = \frac{NI}{2}$$

$$B_m = \mu_0 H$$

$$B_m = \mu_0 \frac{NI}{2g}$$



FMM en el entrehierro. DEVANADO CONCENTRADO DE PASO DIAMETRAL

Alimentación C.C. (Campo fijo)

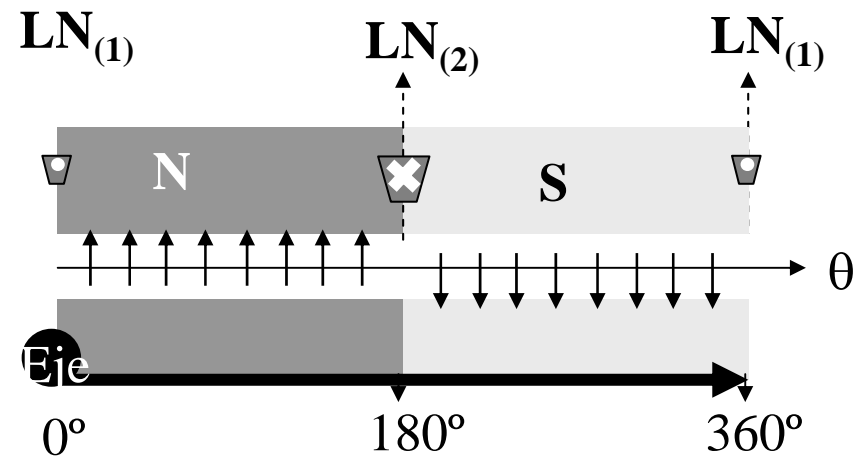
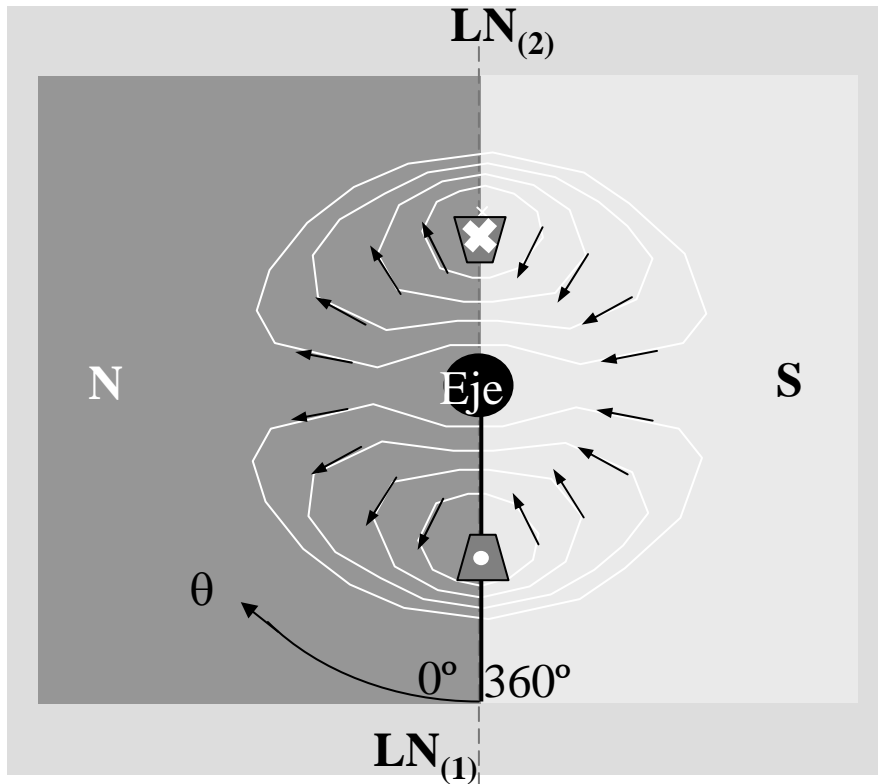



FMM en el entrehierro. DEVANADO CONCENTRADO DE PASO DIAMETRAL

Alimentación C.C. (Campo fijo)

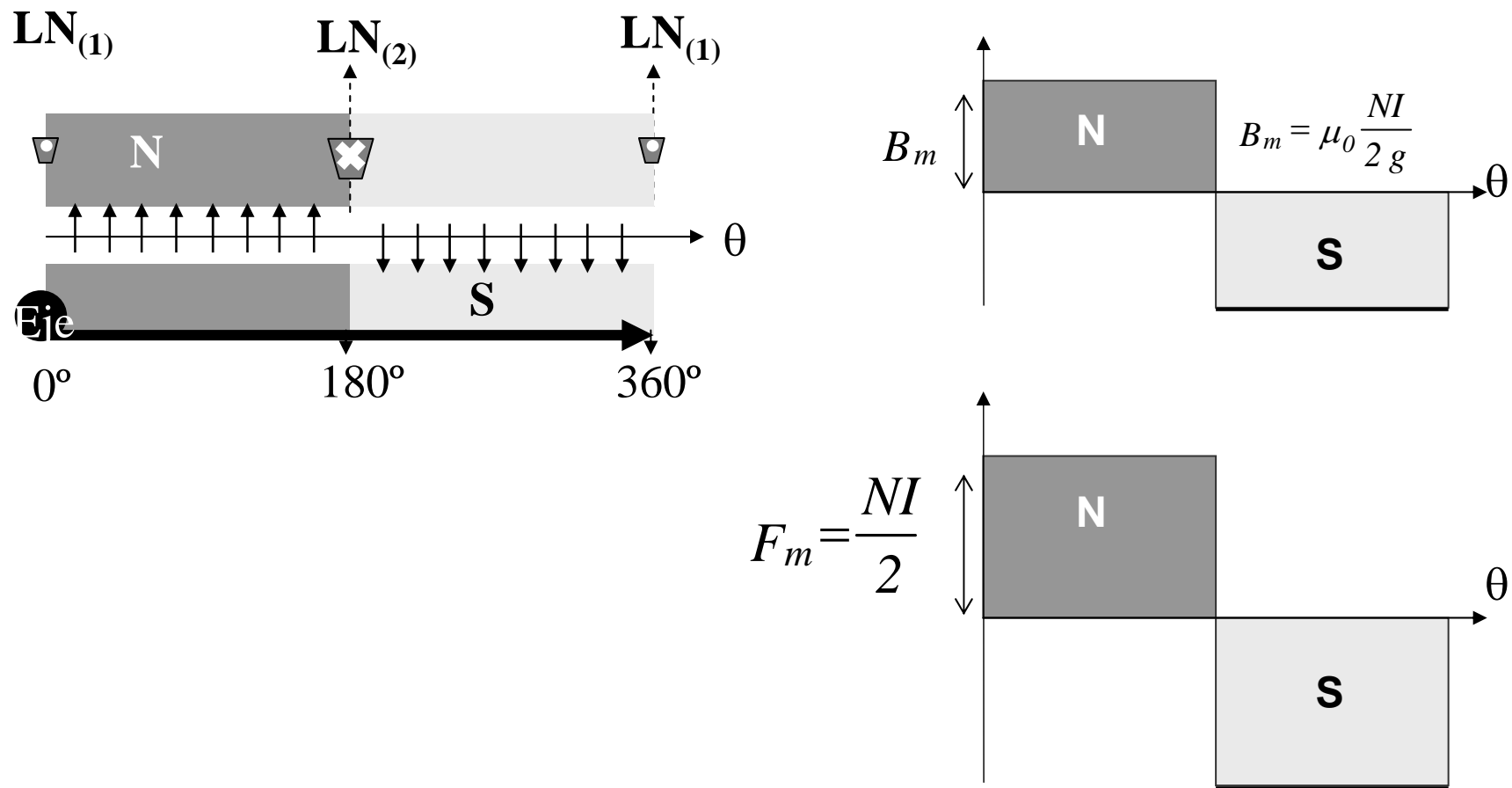



**FMM en el entrehierro. DEVANADO CONCENTRADO DE PASO DIAMETRAL**

Alimentación C.C. (Campo fijo)

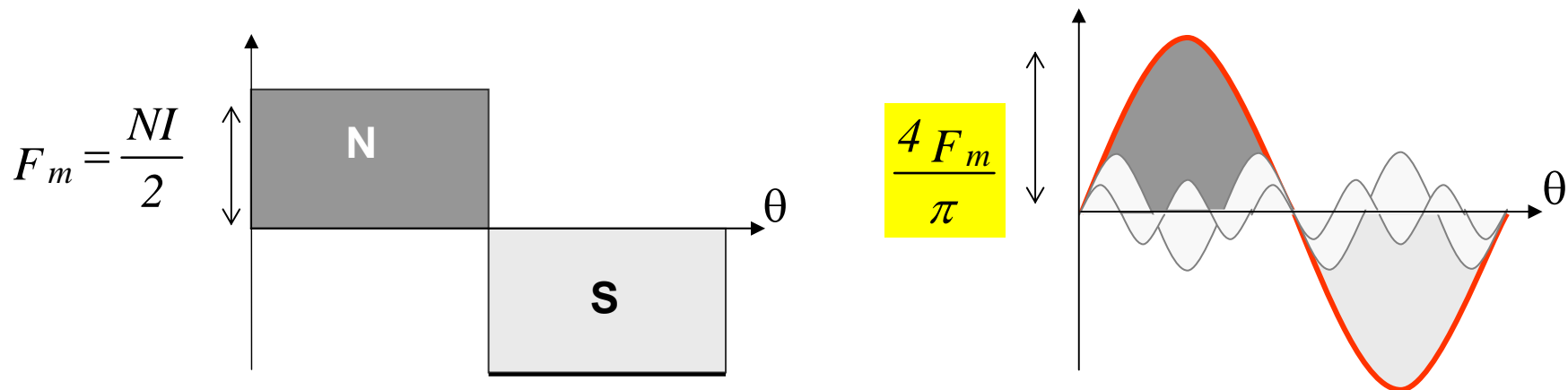

$$F(\theta) = \left[ \frac{4}{\pi} F_m \right] \cos \theta$$

Aplicando Fourier:  $F(\theta) = F_1 \cos \theta + F_2 \cos 2\theta + \dots + F_h \cos h\theta + \dots$

$$F_h = \frac{4}{\pi} \left( \frac{1}{h} \right) F_m \sin\left(\frac{h\pi}{2}\right)$$

$$F(\theta) = \frac{4}{\pi} F_m \left[ \cos \theta - \frac{1}{3} \cos 3\theta + \frac{1}{5} \cos 5\theta + \dots \right]$$



**FMM en el entrehierro. DEVANADO CONCENTRADO DE PASO DIAMETRAL**

Alimentación C.C. (Campo fijo)

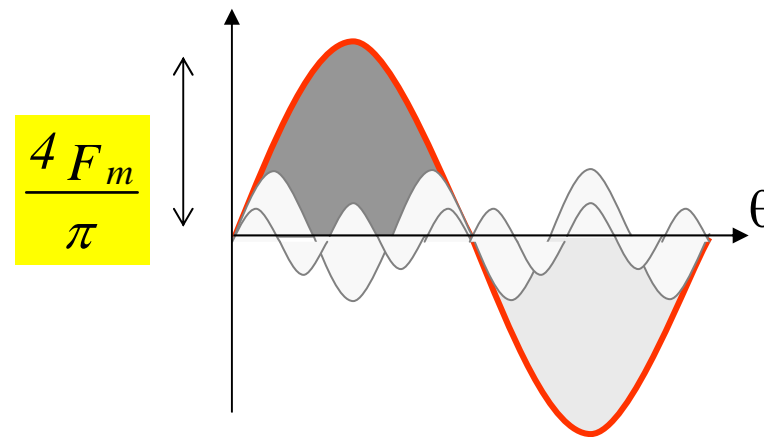

$$F(\theta) = \left[ \frac{4}{\pi} F_m \right] \cos \theta$$



DEVANADO CONCENTRADO DE PASO DIAMETRAL

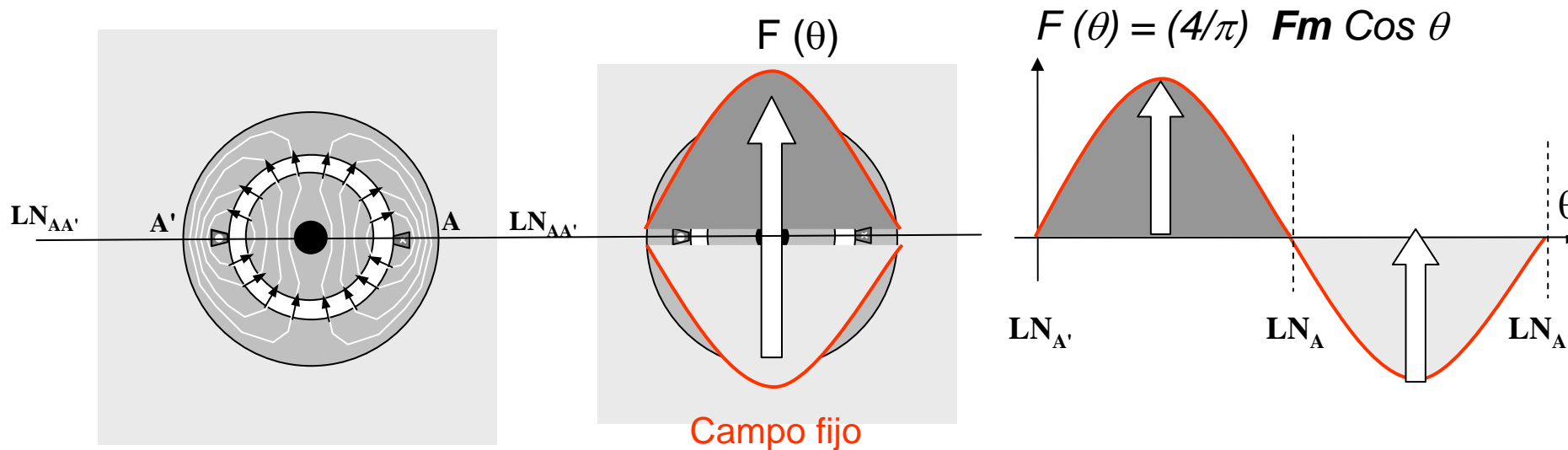
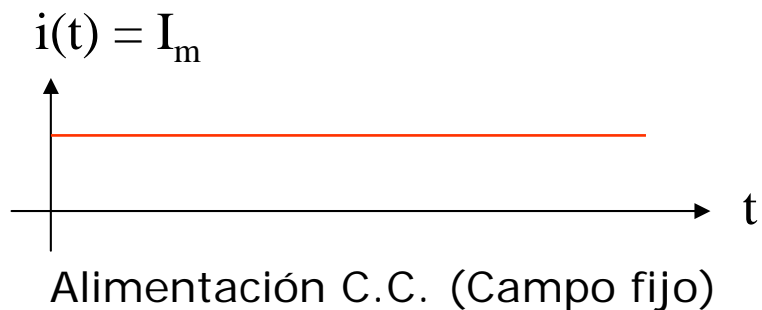

$$F(\theta) = (4/\pi) (N I_m / 2) \cos \theta = (4/\pi) F_m \cos \theta$$



**FMM en el entrehierro** DEVANADO CONCENTRADO DE PASO DIAMETRAL

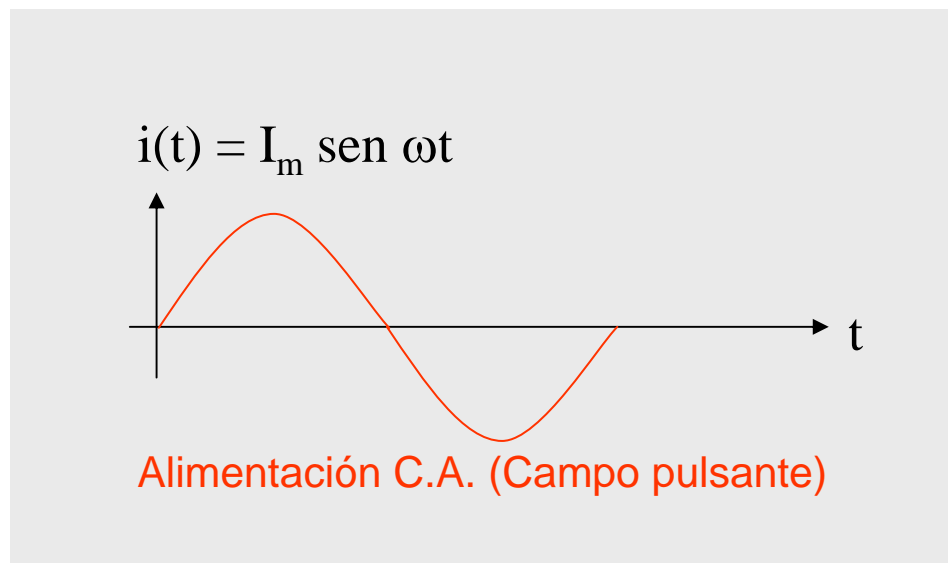
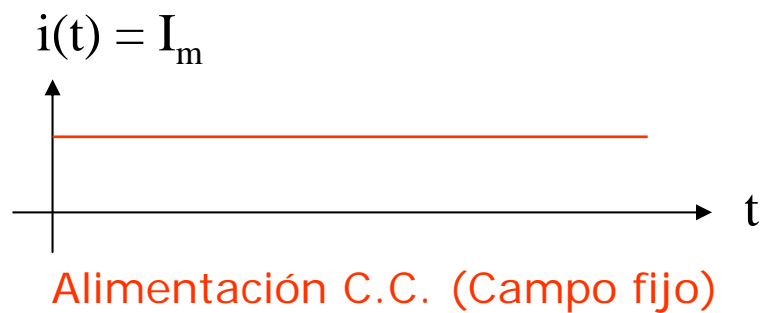



FMM en el entrehierro. DEVANADO CONCENTRADO DE PASO DIAMETRAL

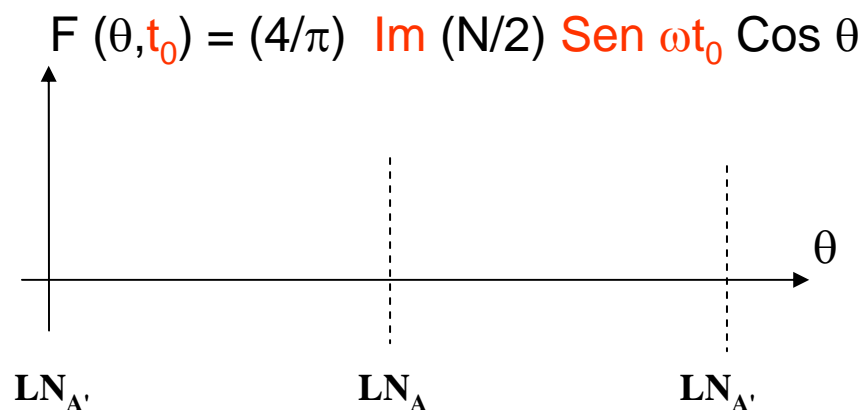
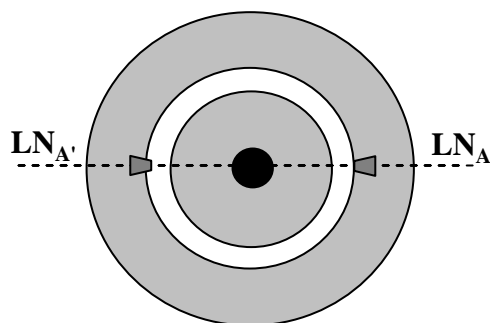
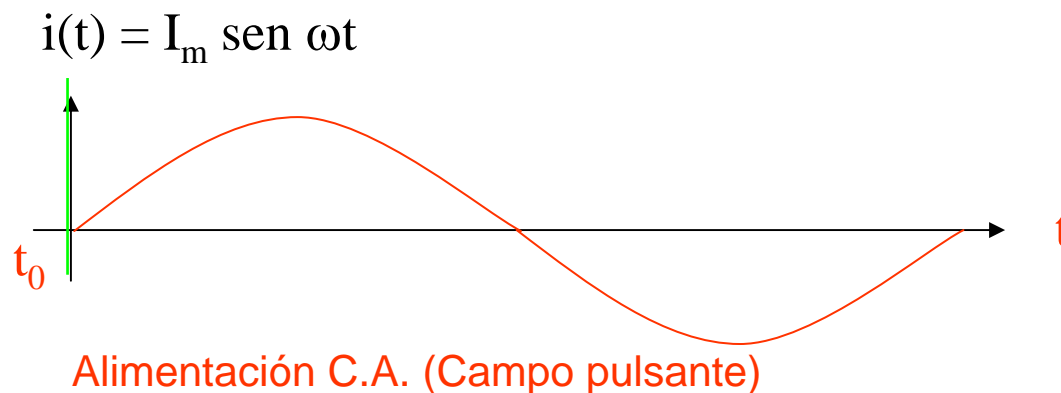

Alimentación C.A. (Campo pulsante)



FMM en el entrehierro. DEVANADO CONCENTRADO DE PASO DIAMETRAL

$$i(t) = I_m \text{sen } \omega t$$

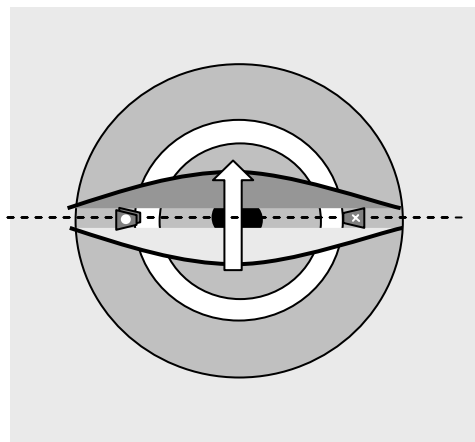
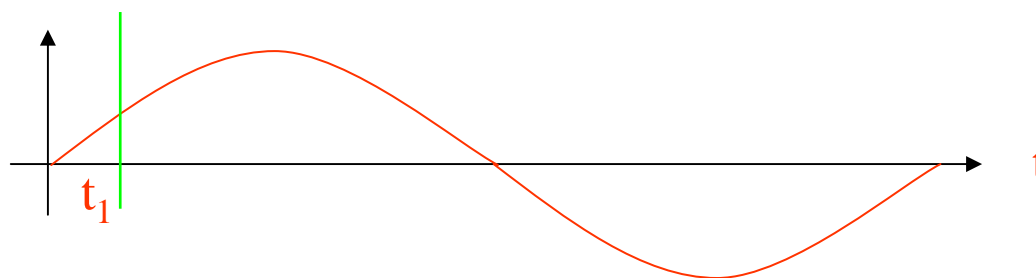

$$F(\theta, t_1) = (4/\pi) I_m (N/2) \text{Sen } \omega t_1 \text{Cos } \theta$$

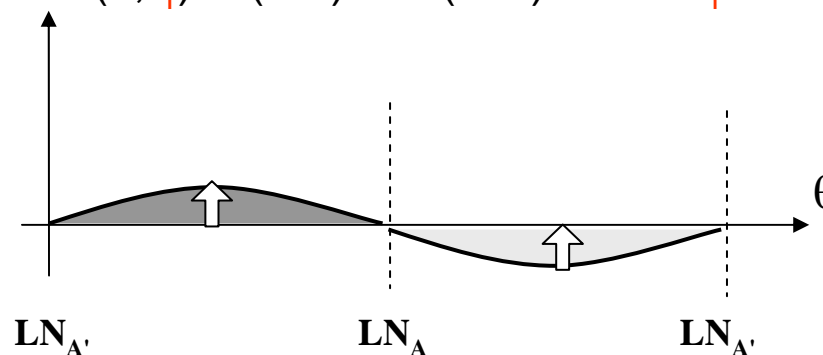

Alimentación C.A. (Campo pulsante)



FMM en el entrehierro. DEVANADO CONCENTRADO DE PASO DIAMETRAL

$$i(t) = I_m \text{sen } \omega t$$

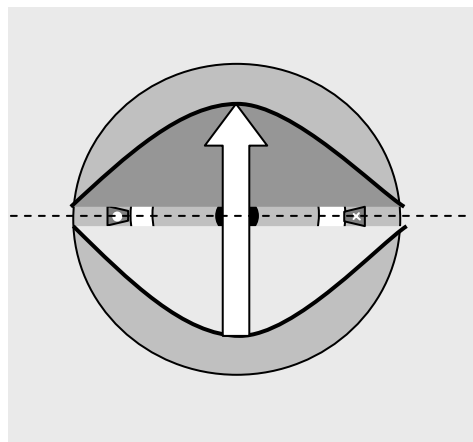
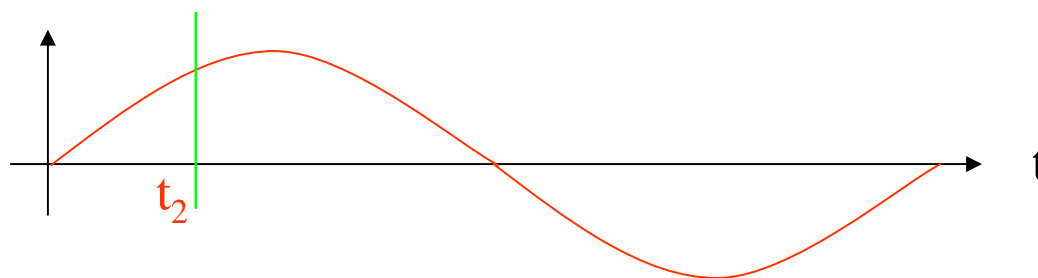

$$F(\theta, t_2) = (4/\pi) I_m (N/2) \text{Sen } \omega t_2 \text{Cos } \theta$$

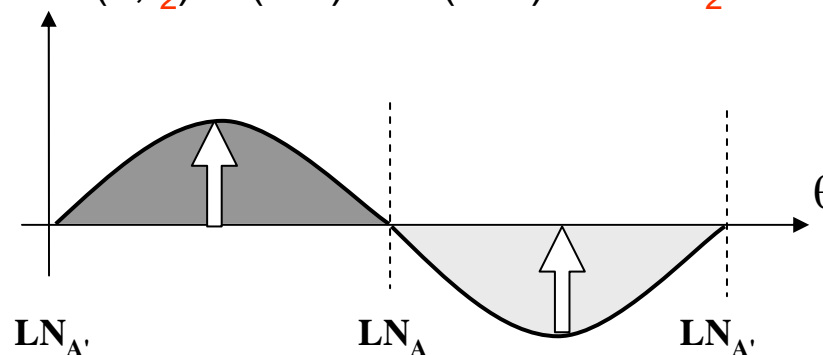

Alimentación C.A. (Campo pulsante)



FMM en el entrehierro. DEVANADO CONCENTRADO DE PASO DIAMETRAL

$$i(t) = I_m \text{sen } \omega t$$

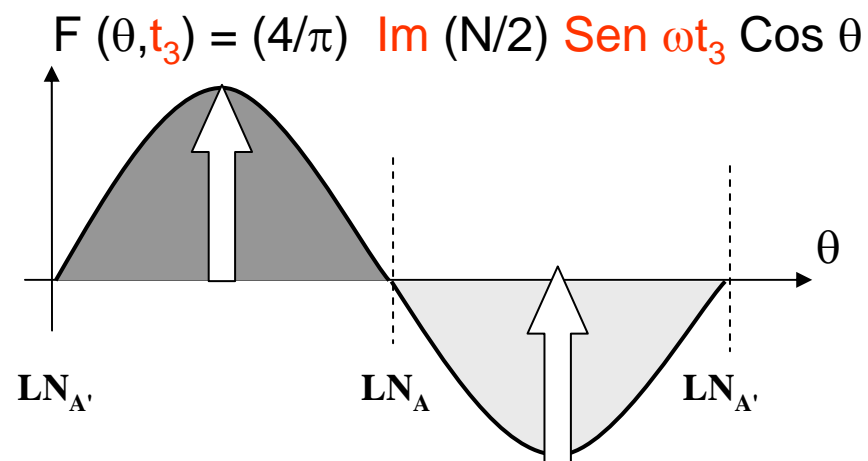
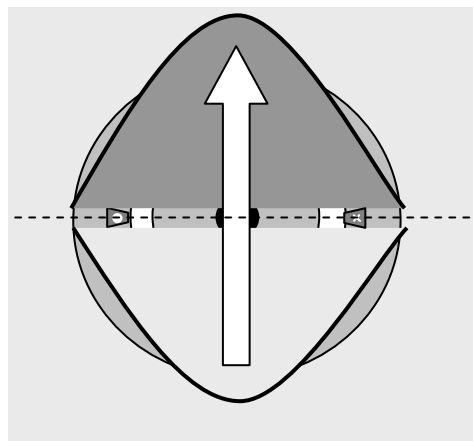
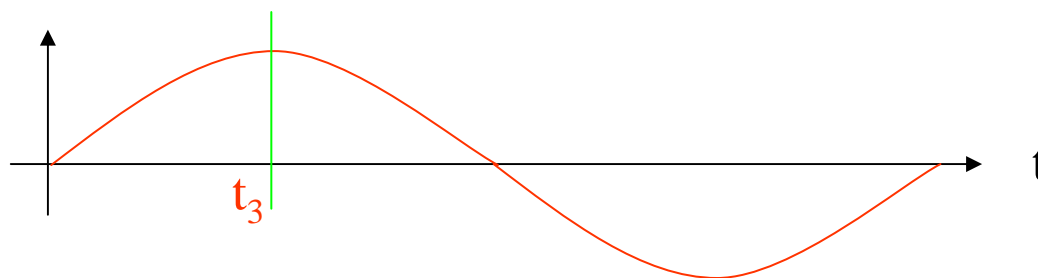

Alimentación C.A. (Campo pulsante)



FMM en el entrehierro. DEVANADO CONCENTRADO DE PASO DIAMETRAL

$$i(t) = I_m \text{sen } \omega t$$

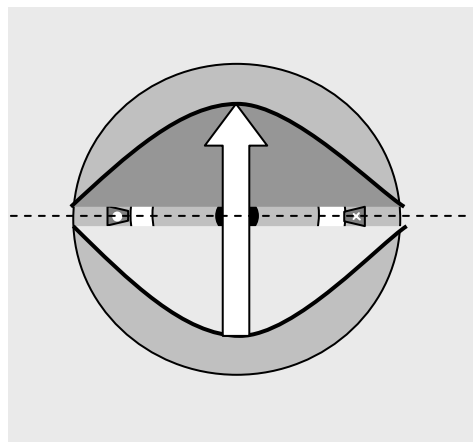
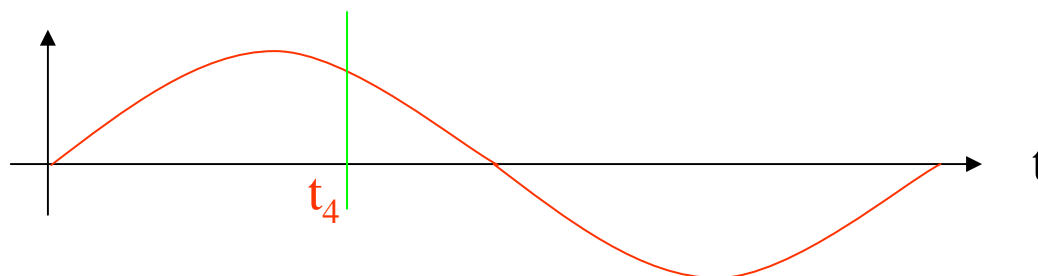

$$F(\theta, t_4) = (4/\pi) I_m (N/2) \text{Sen } \omega t_4 \text{Cos } \theta$$

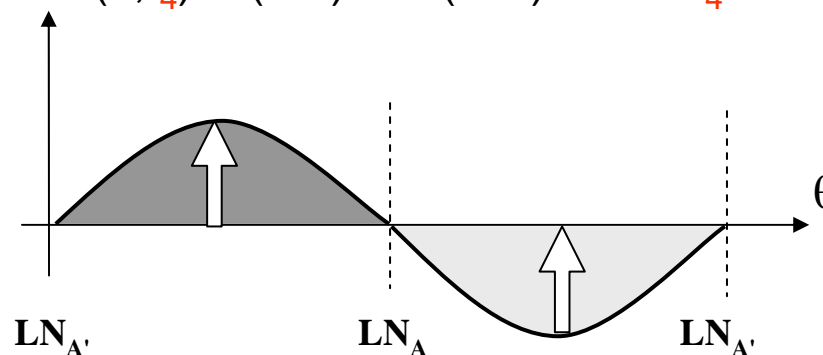

Alimentación C.A. (Campo pulsante)



FMM en el entrehierro. DEVANADO CONCENTRADO DE PASO DIAMETRAL

$$i(t) = I_m \text{sen } \omega t$$

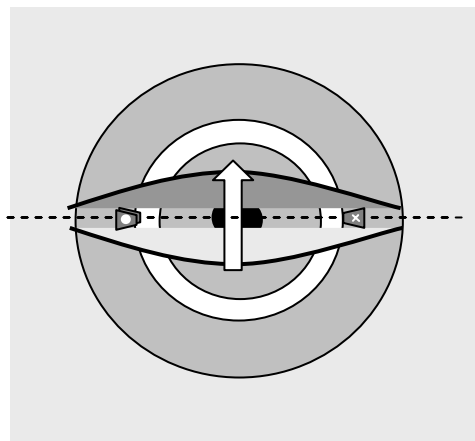
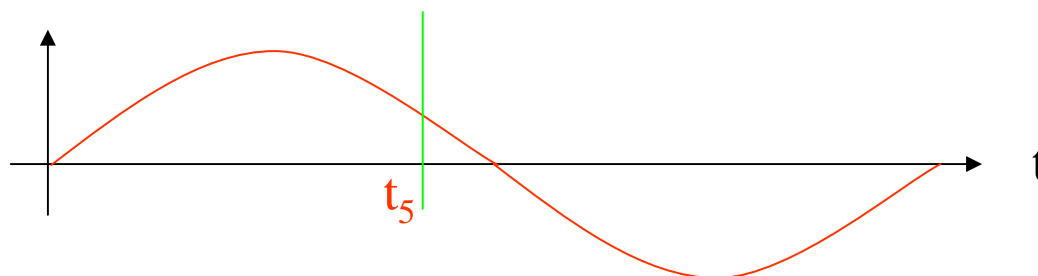

$$F(\theta, t_5) = (4/\pi) I_m (N/2) \text{Sen } \omega t_5 \text{Cos } \theta$$

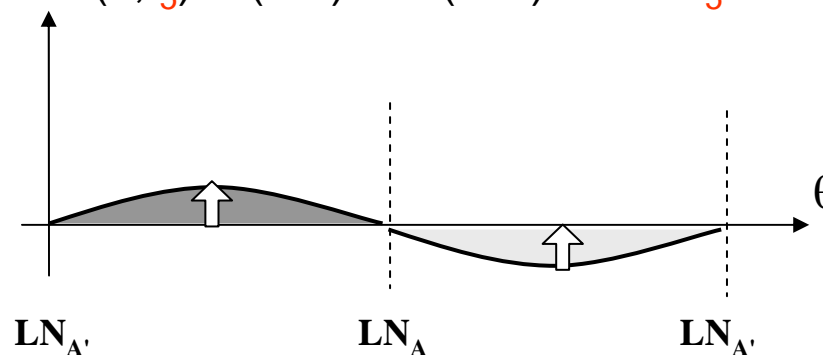

Alimentación C.A. (Campo pulsante)



FMM en el entrehierro. DEVANADO CONCENTRADO DE PASO DIAMETRAL

$$i(t) = I_m \text{sen } \omega t$$

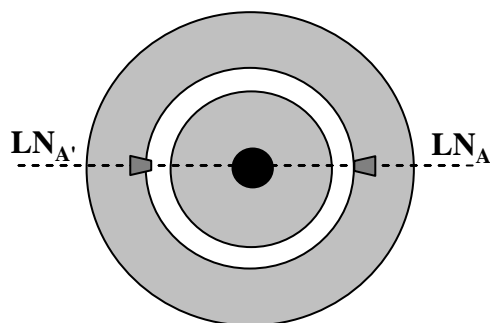
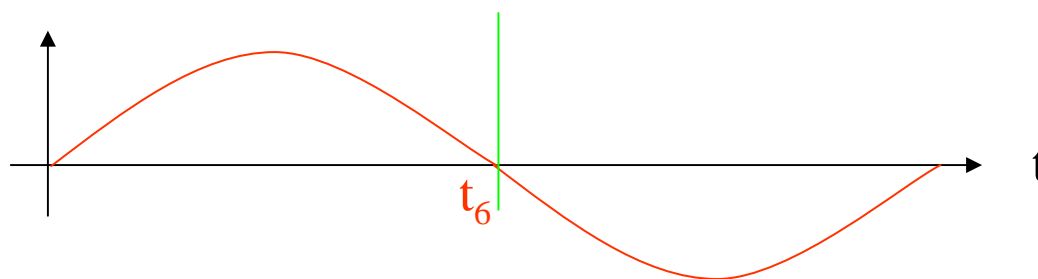

$$F(\theta, t_6) = (4/\pi) I_m (N/2) \text{Sen } \omega t_6 \text{Cos } \theta$$

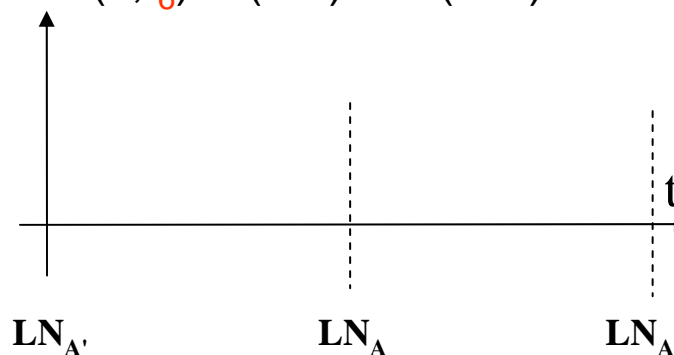

Alimentación C.A. (Campo pulsante)



FMM en el entrehierro. DEVANADO CONCENTRADO DE PASO DIAMETRAL

$$i(t) = I_m \text{sen } \omega t$$

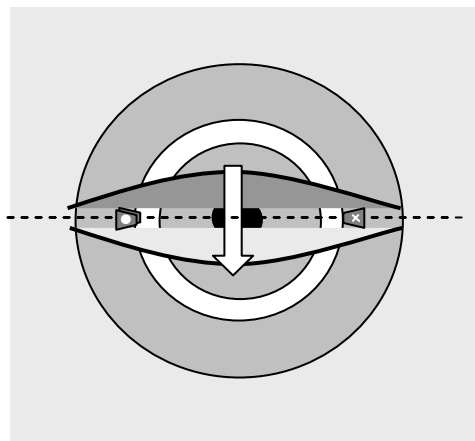
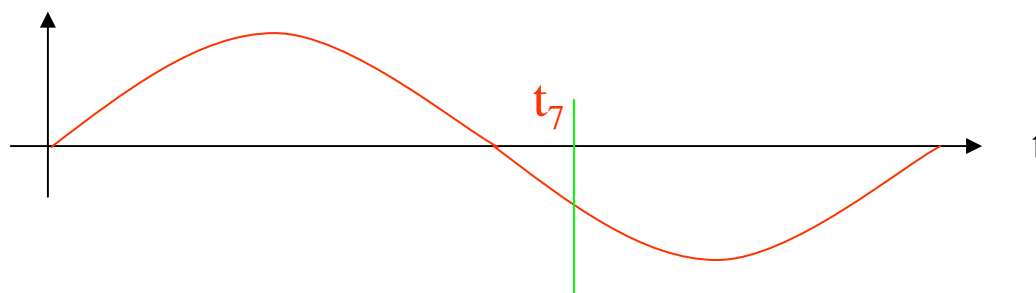

$$F(\theta, t_7) = (4/\pi) I_m (N/2) \text{Sen } \omega t_7 \text{ Cos } \theta$$

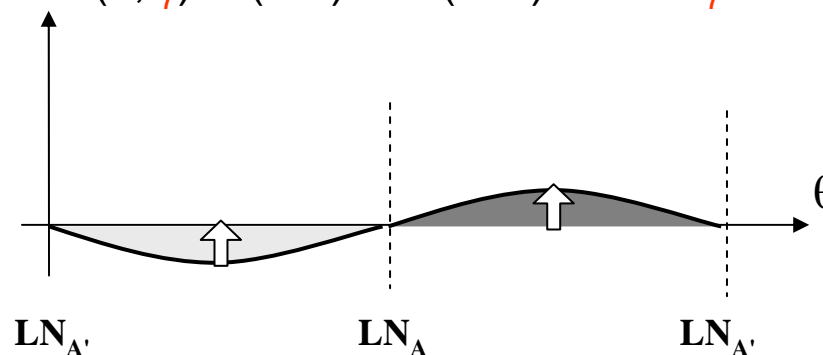

Alimentación C.A. (Campo pulsante)



FMM en el entrehierro. DEVANADO CONCENTRADO DE PASO DIAMETRAL

$$i(t) = I_m \text{sen } \omega t$$

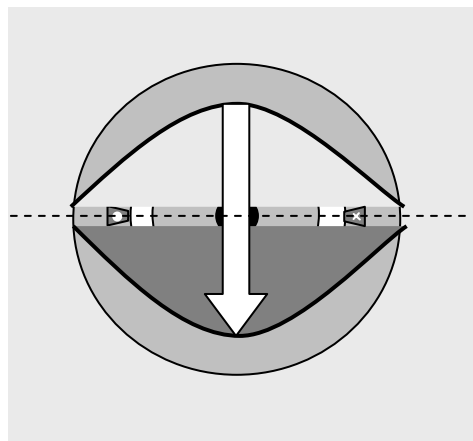
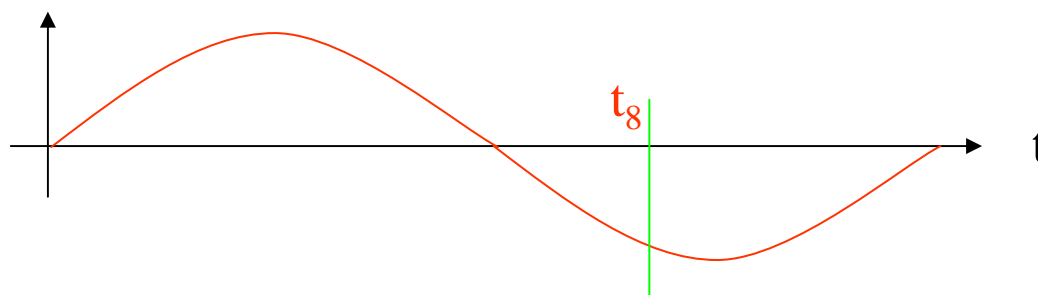

$$F(\theta, t_g) = (4/\pi) I_m (N/2) \text{Sen } \omega t_g \text{Cos } \theta$$

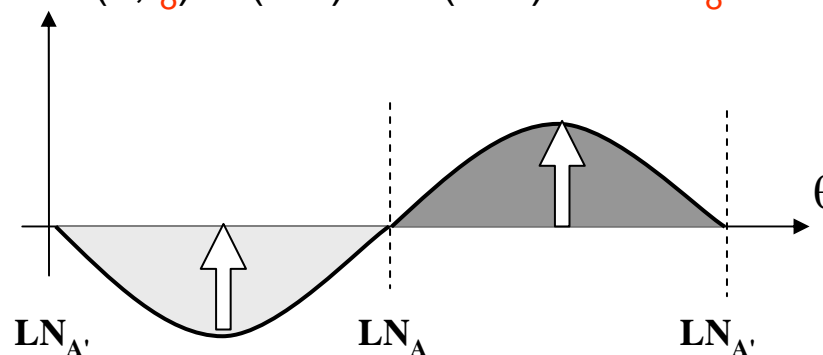

Alimentación C.A. (Campo pulsante)



FMM en el entrehierro. DEVANADO CONCENTRADO DE PASO DIAMETRAL

$$i(t) = I_m \text{sen } \omega t$$

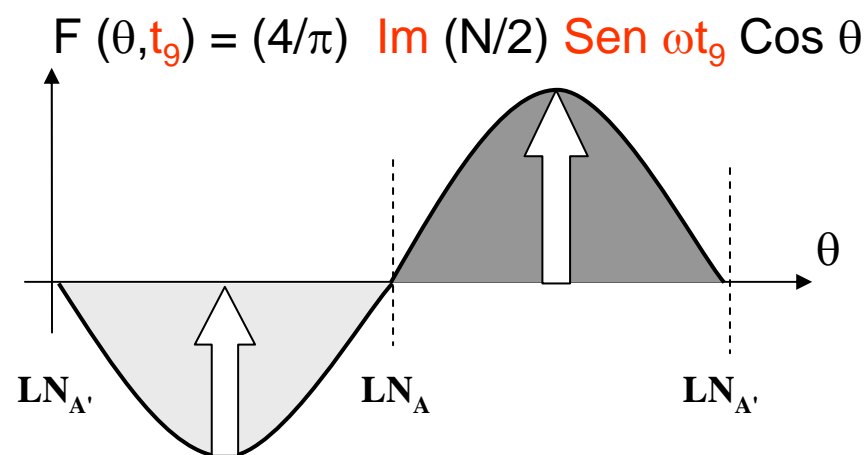
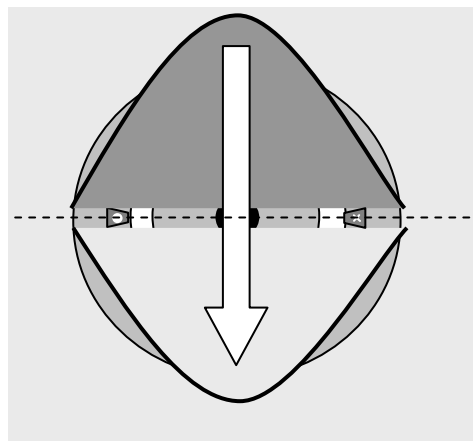
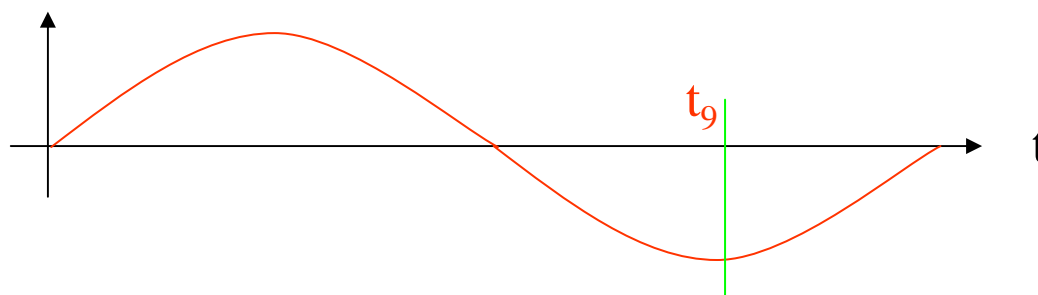

Alimentación C.A. (Campo pulsante)



FMM en el entrehierro. DEVANADO CONCENTRADO DE PASO DIAMETRAL

$$i(t) = I_m \text{sen } \omega t$$

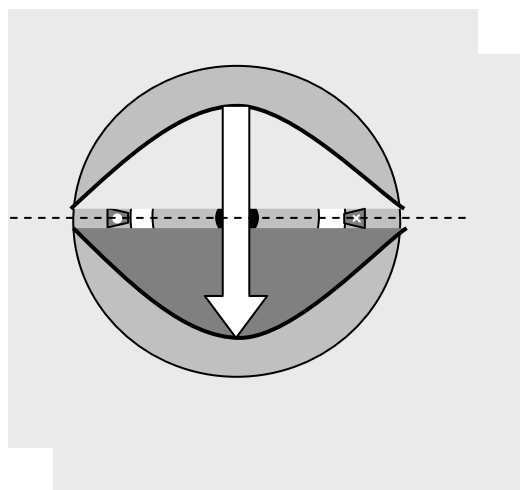
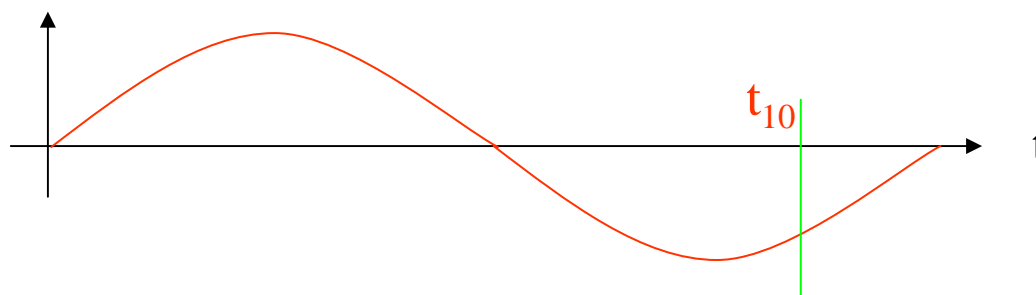

$$F(\theta, t_{10}) = (4/\pi) I_m (N/2) \text{Sen } \omega t_{10} \text{Cos } \theta$$

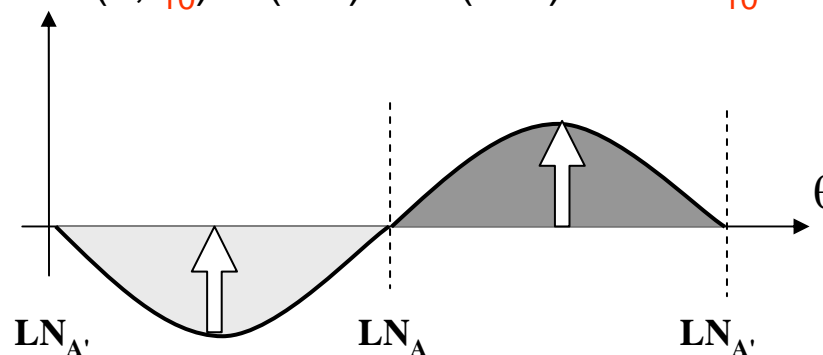

Alimentación C.A. (Campo pulsante)



FMM en el entrehierro. DEVANADO CONCENTRADO DE PASO DIAMETRAL

$$i(t) = I_m \text{sen } \omega t$$

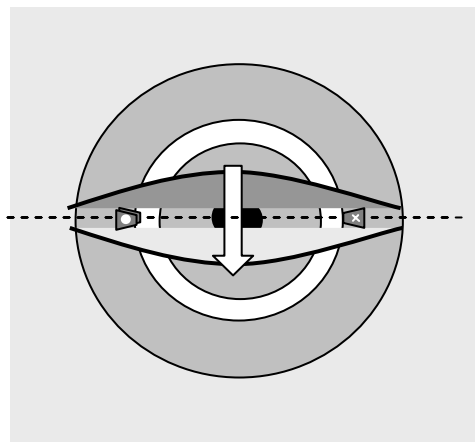
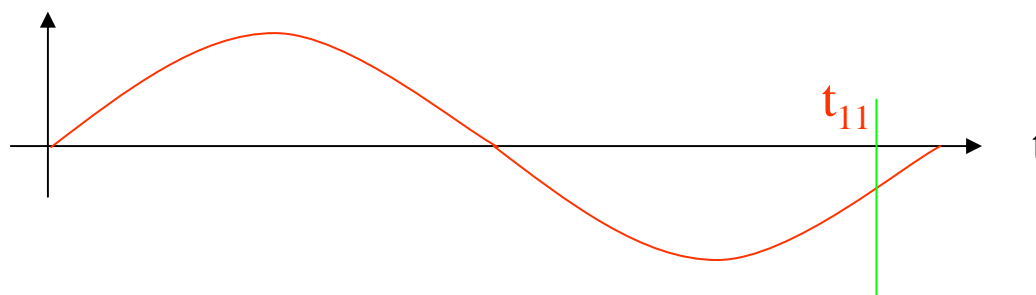

$$F(\theta, t_{11}) = (4/\pi) I_m (N/2) \text{Sen } \omega t_{11} \text{Cos } \theta$$

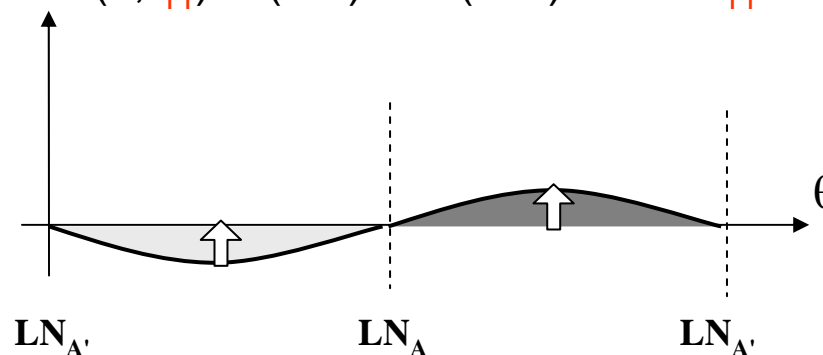

Alimentación C.A. (Campo pulsante)



FMM en el entrehierro. DEVANADO CONCENTRADO DE PASO DIAMETRAL

$$i(t) = I_m \text{sen } \omega t$$

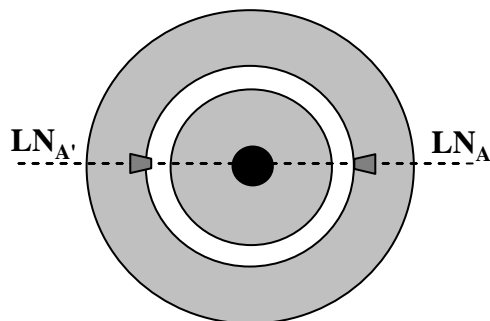
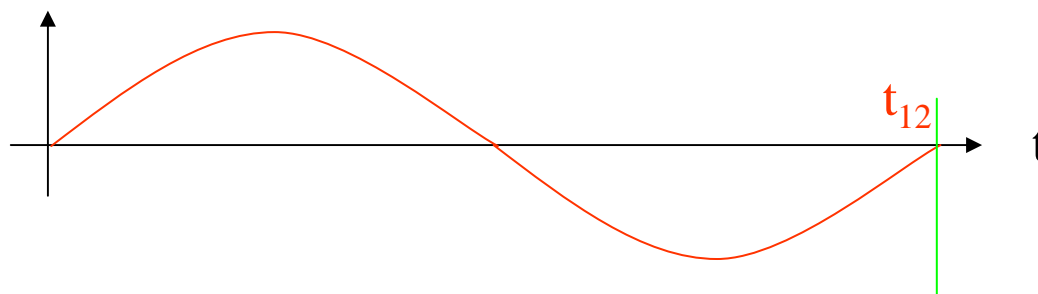

$$F(\theta, t_0) = (4/\pi) I_m (N/2) \text{Sen } \omega t_0 \text{Cos } \theta$$

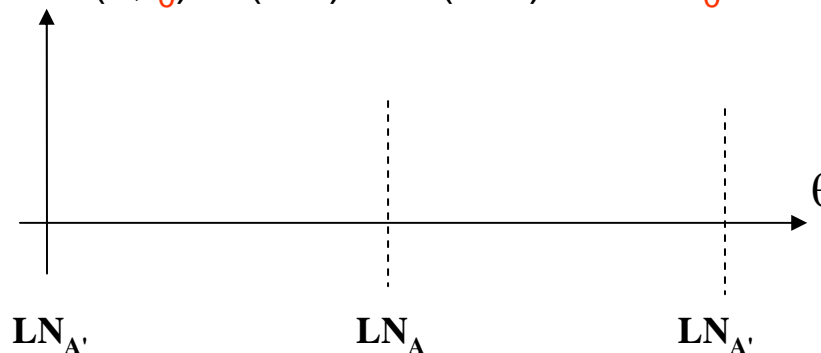

Alimentación C.A. (Campo pulsante)



## FMM en el entrehierro. DEVANADO CONCENTRADO DE PASO DIAMETRAL

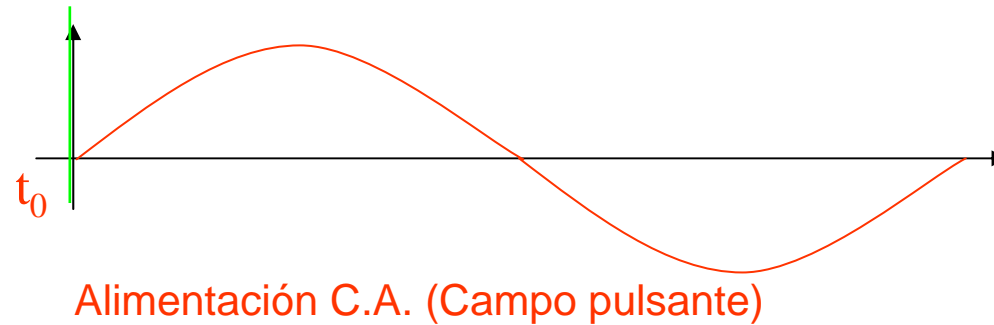

Alimentación C.A. (**Campo pulsante**)



Paso-paso



secuencia



## **FMM en el entrehierro**

DEVANADO CONCENTRADO DE PASO DIAMETRAL

Alimentación C.C. (Campo fijo)

Alimentación C.A. (Campo pulsante)

**DEVANADO DISTRIBUIDO DE PASO DIAMETRAL**

CAMPO GIRATORIO

Teorema de Ferraris

Teorema de Leblanc

FEM INDUCIDA EN EL DEVANADO DE LA M.E.



FMM en el entrehierro. **DEVANADO DISTRIBUIDO DE PASO DIAMETRAL**

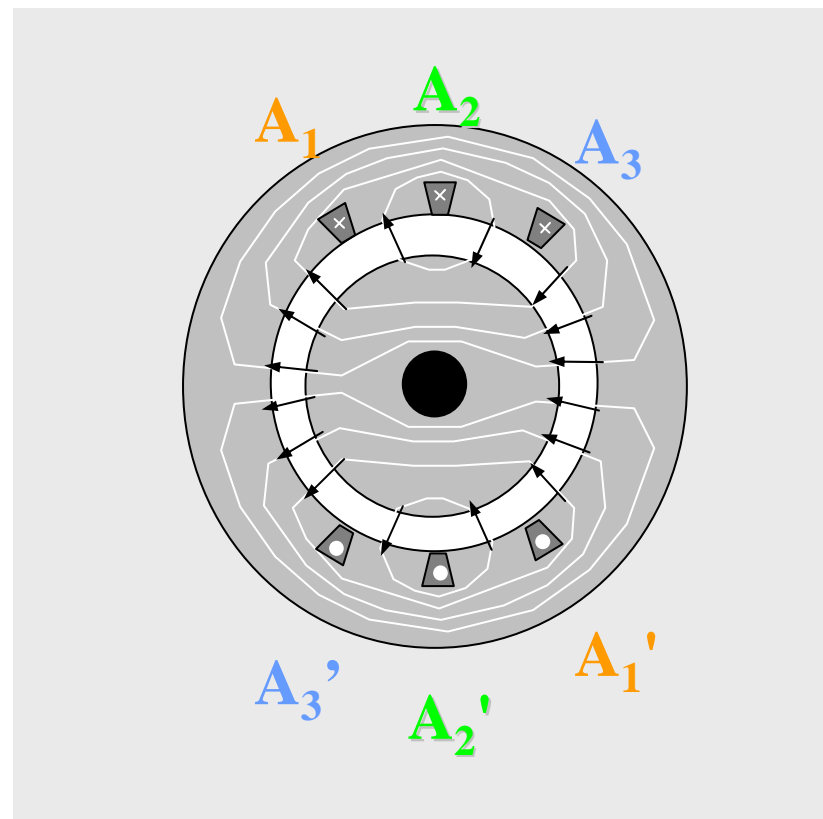
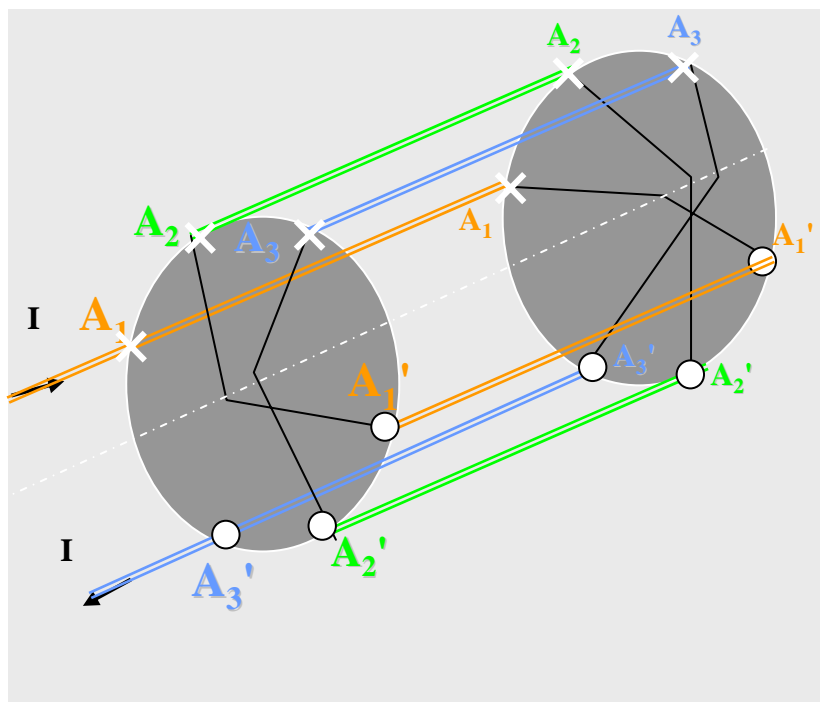



FMM en el entrehierro.

~~DEVANADO DISTRIBUIDO DE PASO DIAMETRAL~~  
CONCENTRADO

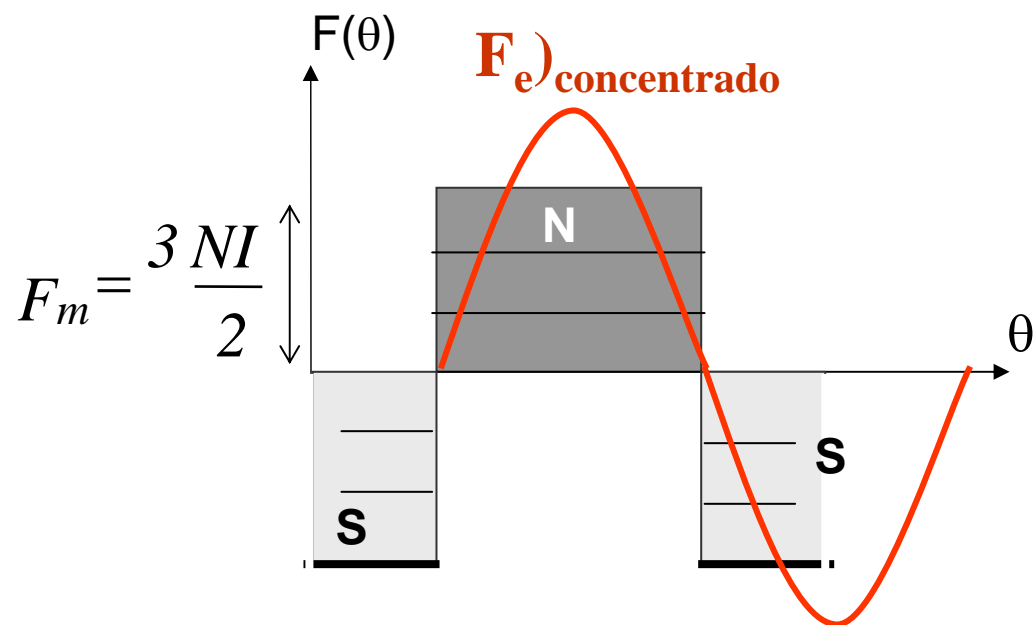
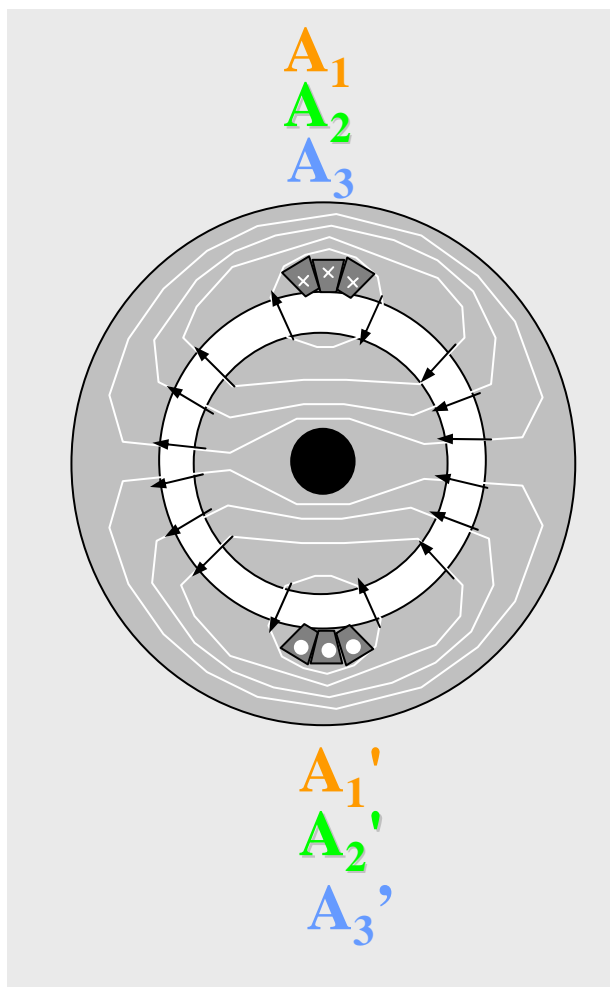



FMM en el entrehierro.

~~DEVANADO DISTRIBUIDO DE PASO DIAMETRAL~~  
CONCENTRADO

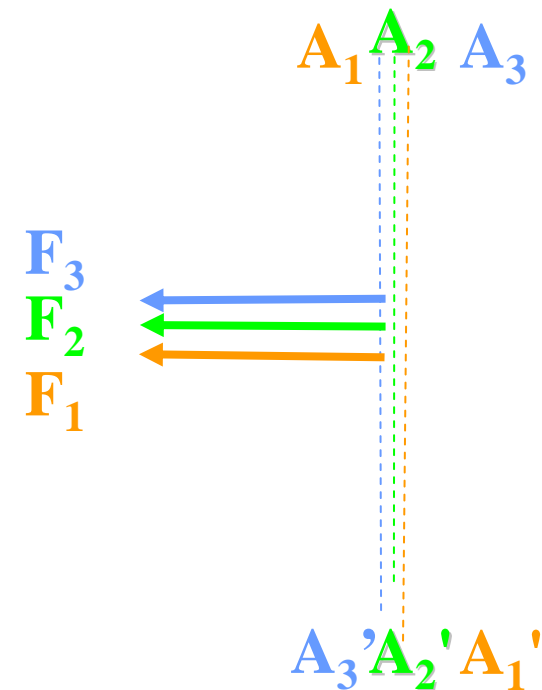
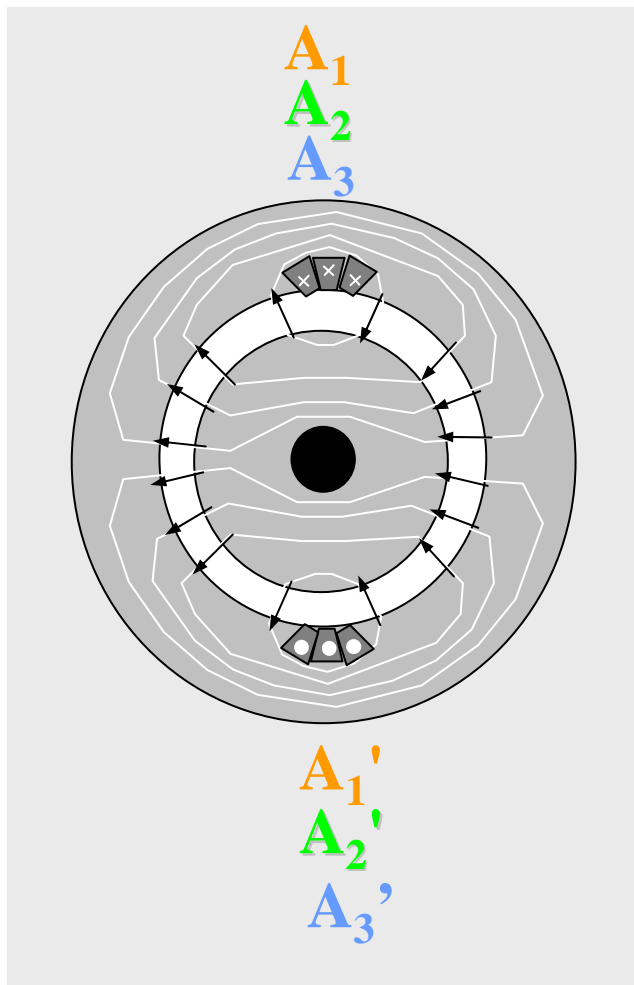



FMM en el entrehierro.

~~DEVANADO DISTRIBUIDO DE PASO DIAMETRAL~~  
CONCENTRADO

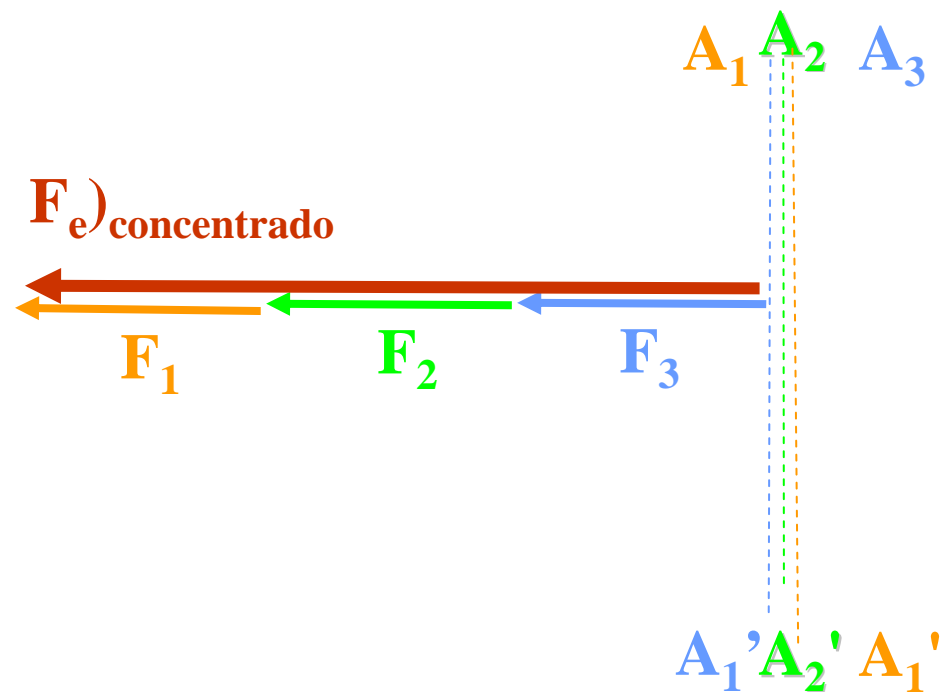
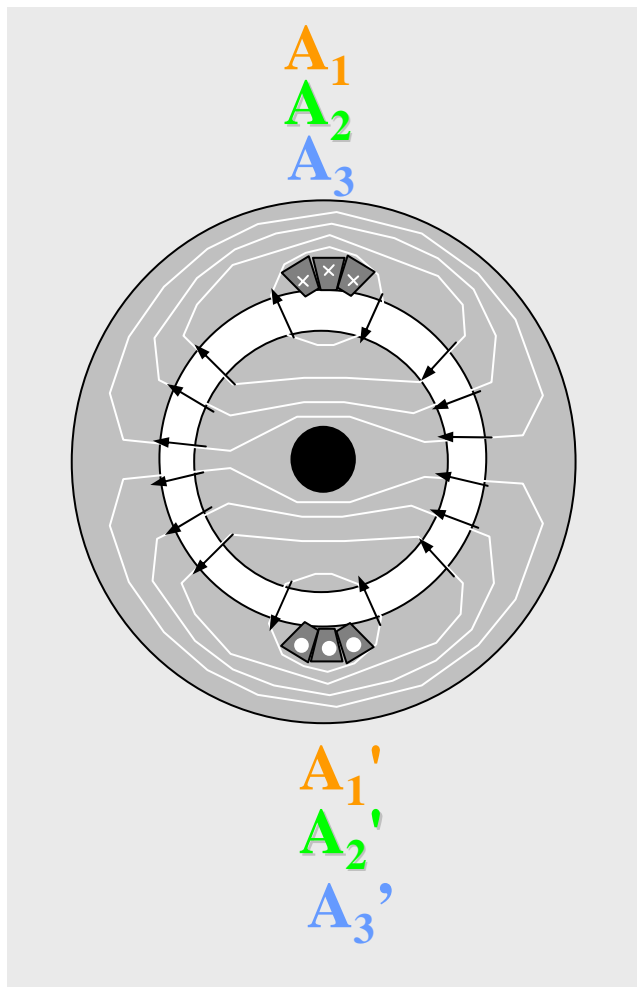



FMM en el entrehierro.

DEVANADO DISTRIBUIDO DE PASO DIAMETRAL

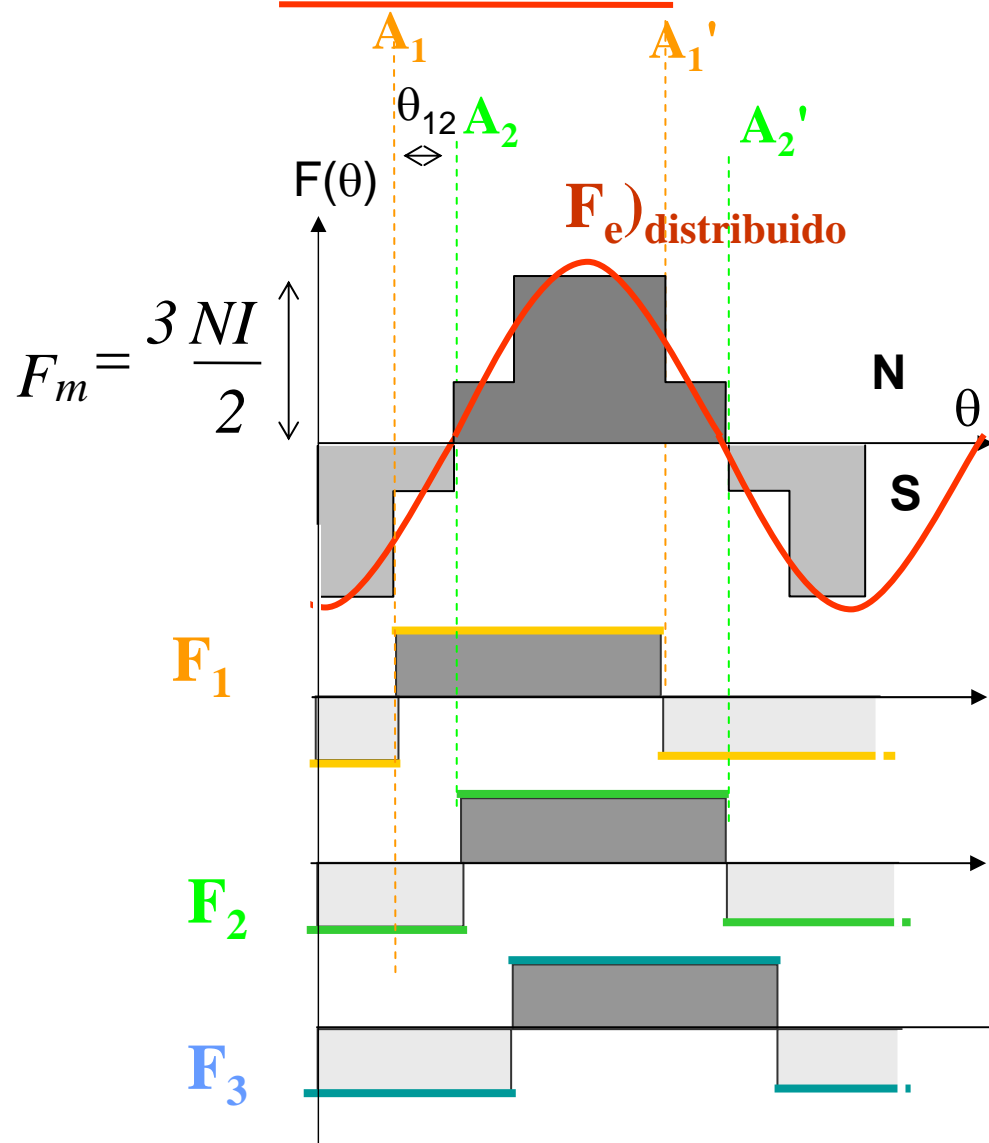
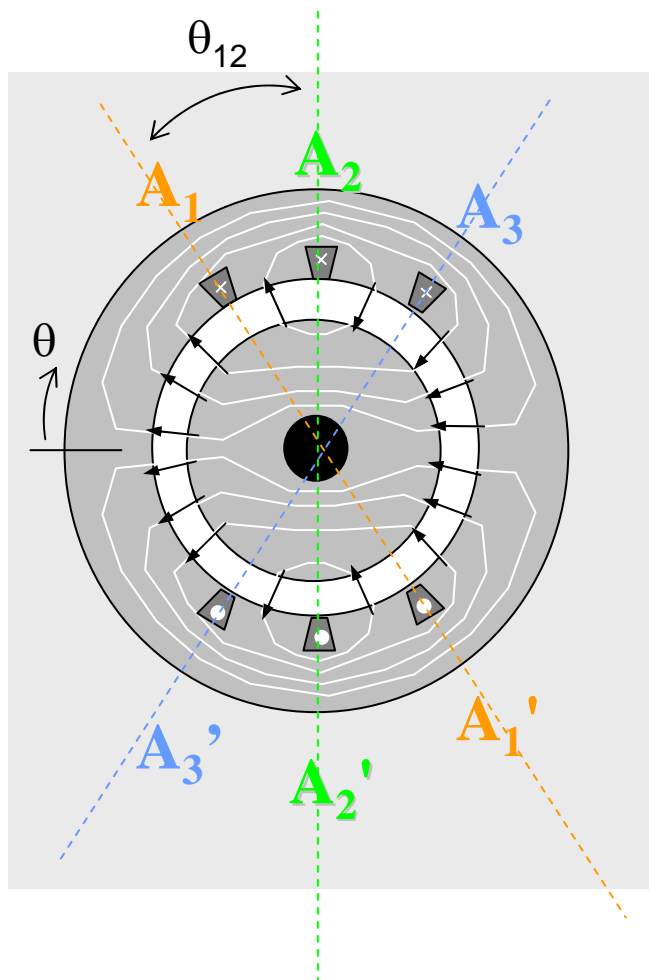



FMM en el entrehierro.

DEVANADO DISTRIBUIDO DE PASO DIAMETRAL

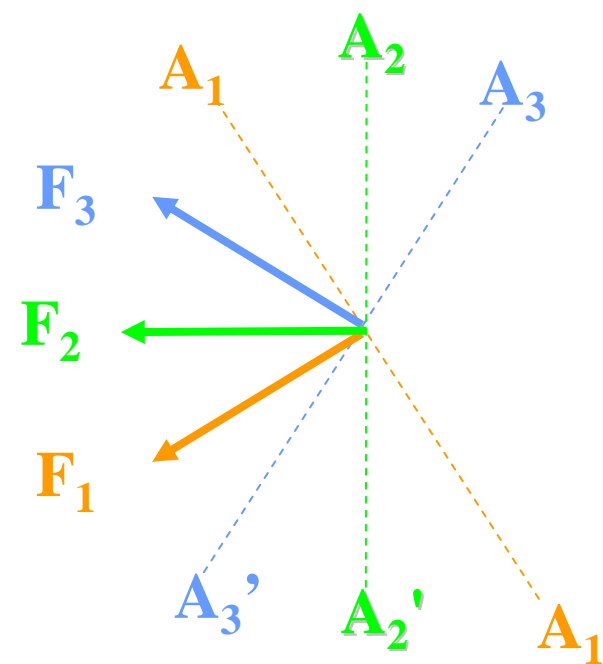
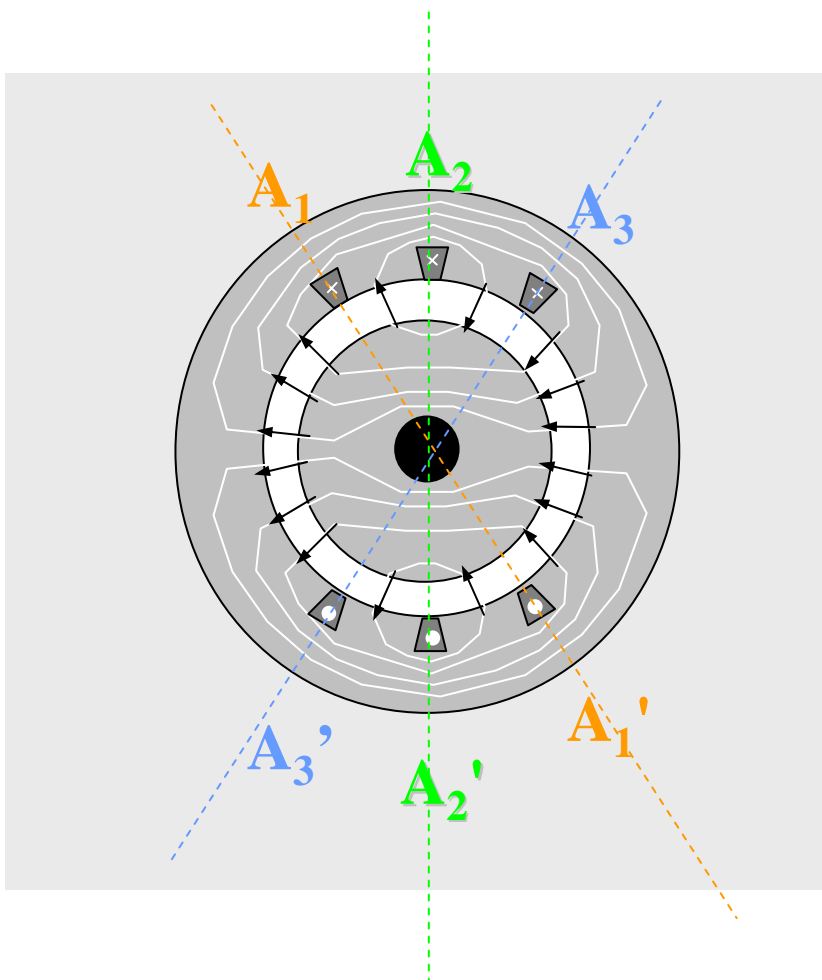



FMM en el entrehierro.

DEVANADO DISTRIBUIDO DE PASO DIAMETRAL

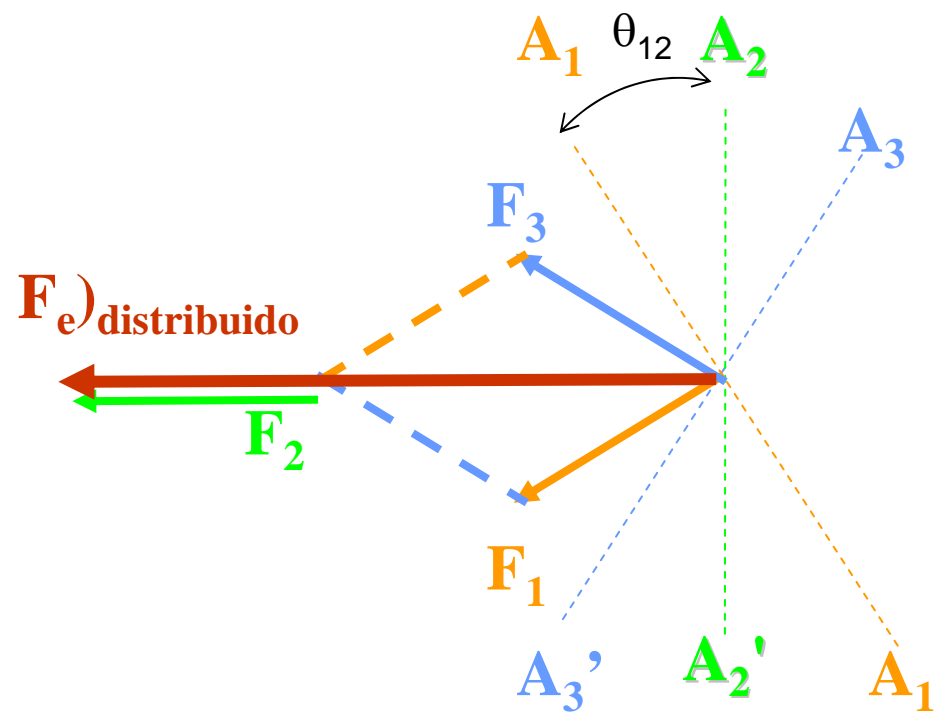
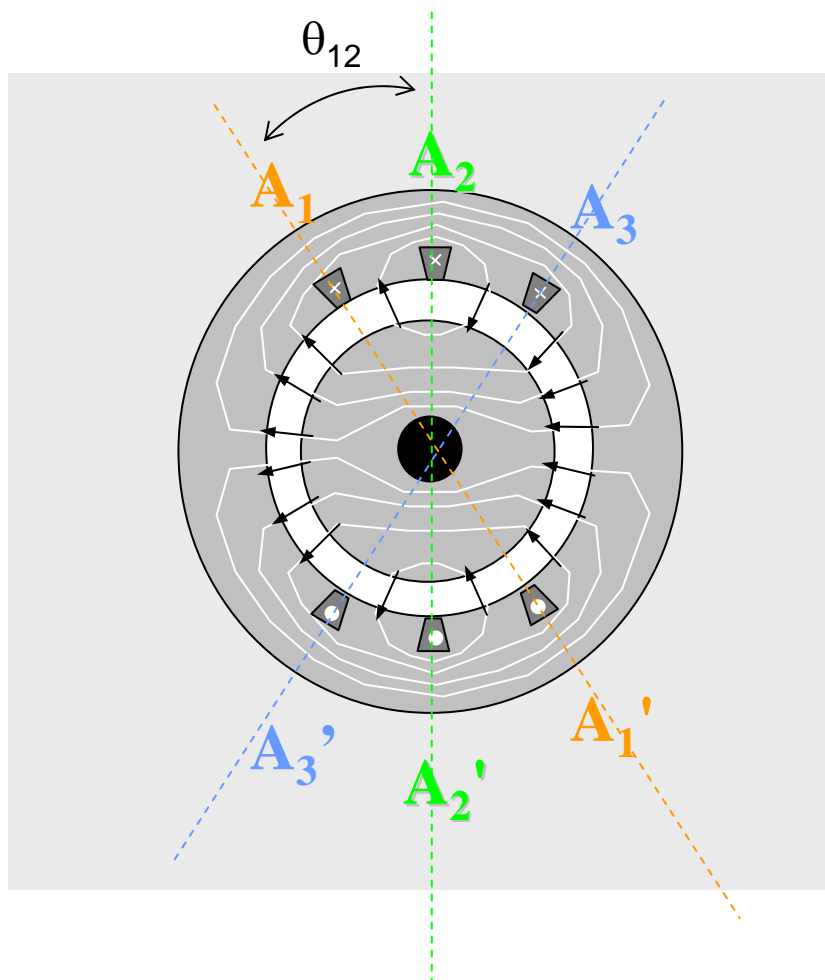



FMM en el entrehierro.

DEVANADO DE PASO DIAMETRAL

DEVANADO CONCENTRADO

$A_3$   $A_2$   $A_1$

DEVANADO DISTRIBUIDO

$A_1$   $A_2$   $A_3$

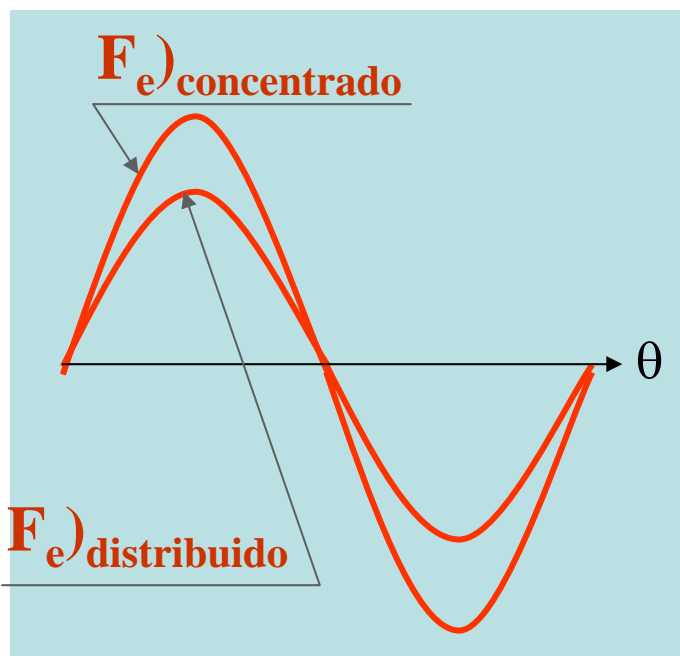
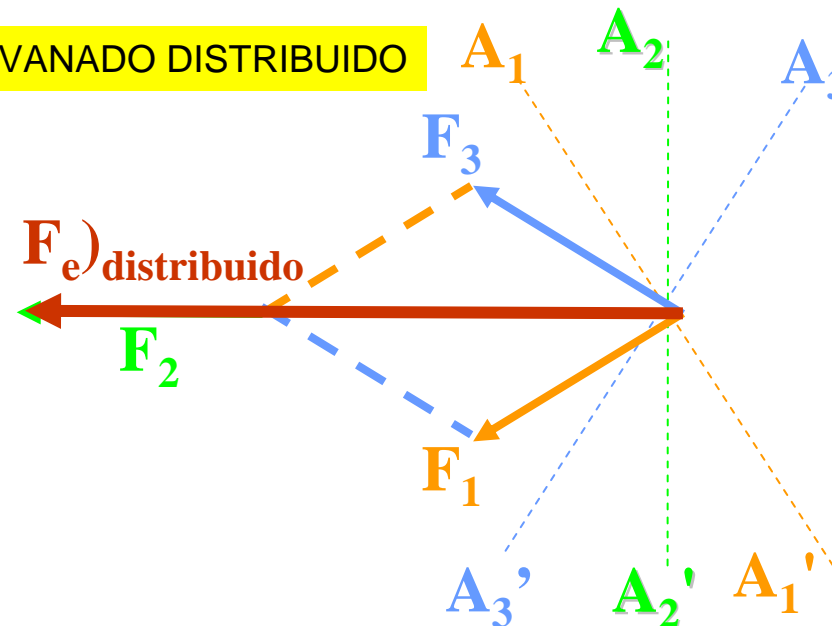
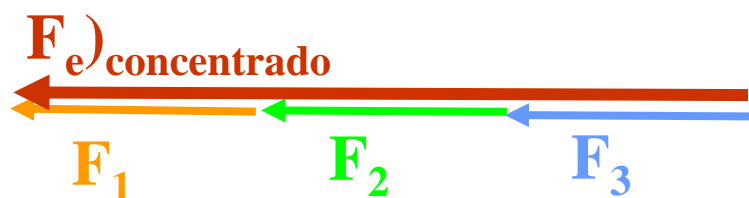

$A_1'$   $A_2'$   $A_3'$

Kd : Factor de distribución

$$Kd = \frac{F_e)_{distribuido}}{F_e)_{concentrado}}$$



FMM en el entrehierro.

**DEVANADO DISTRIBUIDO DE PASO DIAMETRAL**

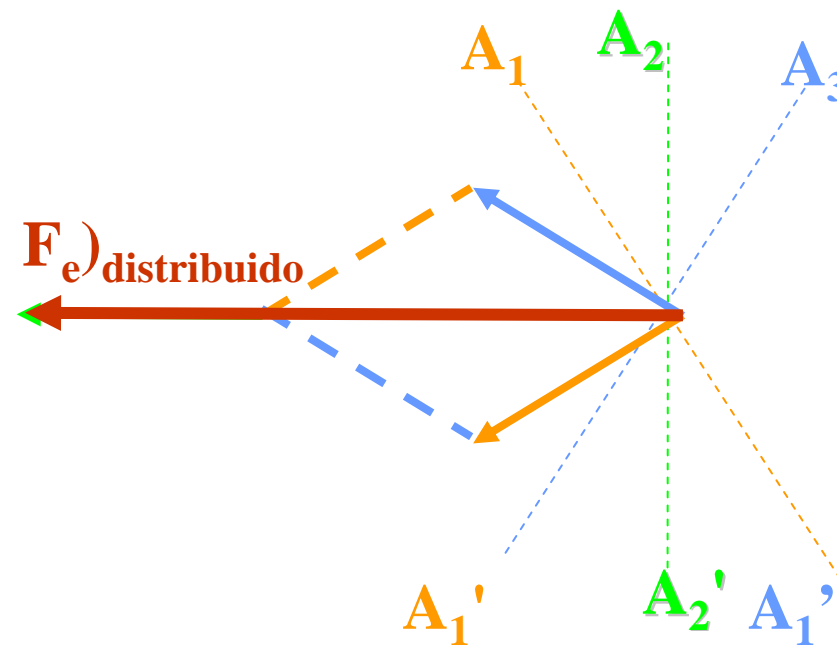
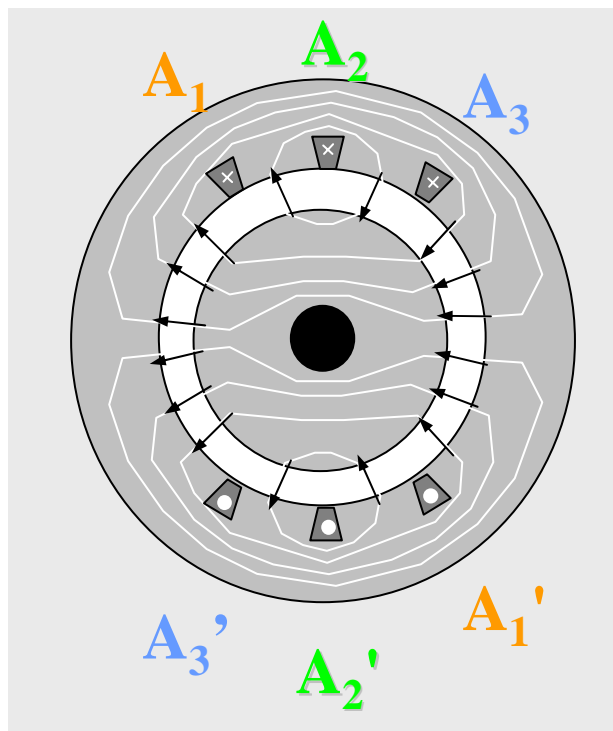

$$F(\theta, t) = \frac{4}{\pi} 3 K_d \left( \frac{N i(t)}{2} \right) \cos \theta = \frac{4}{\pi} 3 K_d \left( \frac{N I_m}{2} \right) \cos \omega t \cos \theta$$

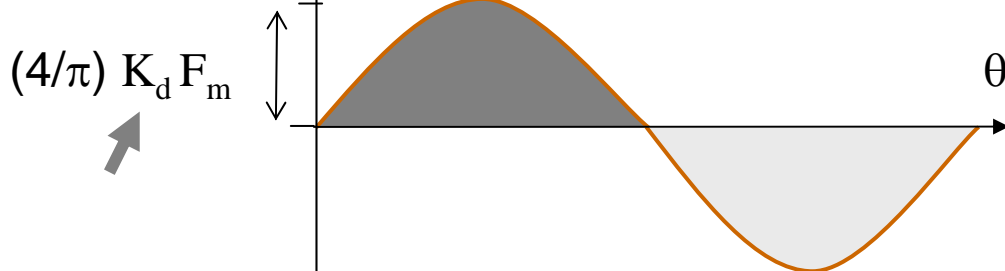



## FMM en el entrehierro. GENERALIZACIÓN

### DEVANADO DISTRIBUIDO DE PASO DIAMETRAL

$N_f$ : espiras por (devanado/fase)

Corriente alterna:  $i(t) = I_m \text{ sen } \omega t$

$2p$  polos

$$2p F_m(t) = N_f i(t)$$

$$F_m = \frac{N_f I_m}{2p}$$

$$F(\theta, t) = (4/\pi) K_d \overbrace{(N_f I_m / 2p)}^{F_m} \text{Cos } \omega t \text{ Cos } \theta$$

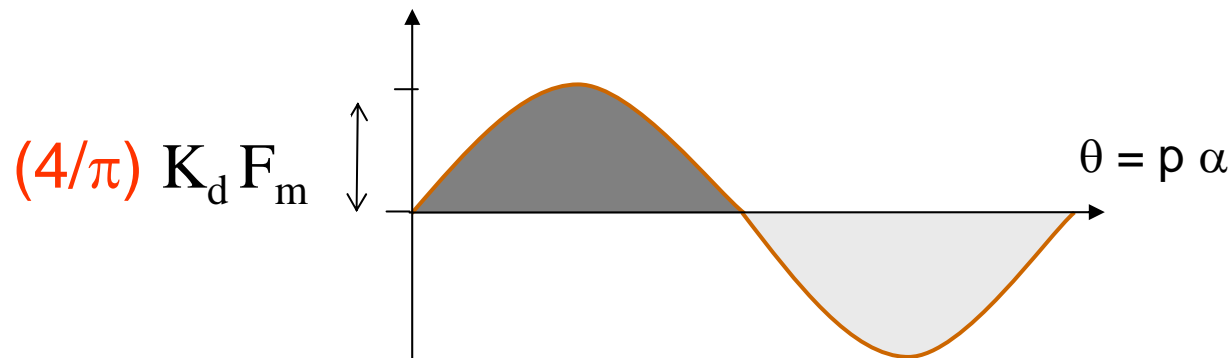



## **FMM en el entrehierro y FEM inducida en la M.E.R.**

DEVANADO CONCENTRADO DE PASO DIAMETRAL

Alimentación C.C. (Campo fijo)

Alimentación C.A. (Campo pulsante)

DEVANADO DISTRIBUIDO DE PASO DIAMETRAL

### **CAMPO GIRATORIO**

Teorema de Ferraris

Teorema de Leblanc

FEM INDUCIDA EN EL DEVANADO DE LA M.E.