

# A Control Algorithm for Coordinated Reactive Power Compensation in a Wind Park

E. Díaz-Dorado, C. Carrillo and J. Cidrás, *Member, IEEE*

**Abstract**— The penetration level of wind energy is continuously growing, and it is especially relevant in European countries as Denmark, Germany and Spain. For this reason, grid codes in different countries have been recently revised, or are now under revision in order to integrate this energy in the network taking into account the security of supply. This paper is related to reactive compensation, which is one aspect usually included in these codes.

In the other hand, a great number of installed wind parks are formed by fixed speed wind turbines equipped with induction generators. The typical scheme for reactive compensation in this kind of wind parks is based in capacitor banks locally controlled in each machine. This configuration makes very difficult to follow the requirements of the new grid codes.

To overcome this problem, a configuration with a central controller that coordinates the actuation over all the capacitor steps in the wind park is proposed in this article. A central controller algorithm which is based on a dynamic programming is presented and evaluated by means of simulation.

At this time, the proposed scheme has been installed at the Sotavento Experimental Wind Park (Spain) and it is currently being tested.

**Index Terms**— Wind energy, Reactive power control, Dynamic programming

## I. INTRODUCTION

From last years findings, the presence of wind energy in the generation share has been continuously increasing. During 2005, the average annual penetration level for wind energy was approx 23% in West Denmark, 8% in Spain and 5% in Germany. These levels represent a serious challenge for the electrical grids due to the nature of wind and the technology of wind turbines.

Transmission system operators (TSO) must adapt their grid codes for enabling wind generation to connect to the transmission ensuring the security of supply. Active power control, frequency control, voltage control, reactive power compensation or voltage sag immunity are aspects that have been regulated in different grid codes around the world. The main focus of this paper is the reactive power compensation,

This work was produced as part of a research project and was supported by Sotavento Galicia, S.A.

E. Díaz-Dorado, C. Carrillo and J. Cidrás work for the Department of Electrical Engineering (University of Vigo) ETSEI, Campus Universitario, 36310 Vigo, Spain (phone: +34986813912; fax: +34986812173; e-mail: ediaz@uvigo.es; carrillo@uvigo.es; jcidras@uvigo.es).

which is a common aspect regulated by the TSO's in Spain, Germany, Denmark, Scotland... [2][3][4][5]

An important amount of the wind turbines currently operating around the world are fixed speed ones based on conventional cage induction generators, e.g. in Spain the installed capacity of this technology was 34% in 2006, and in Denmark it was more than 70% in 2005.

The reactive compensation in wind parks formed by this type of machines is commonly done through capacitors banks, which are divided in steps, installed in the LV side of wind turbines and in the MV side of substation [1]. Each set of capacitors is controlled by its own Power Factor Controller (PFC), which could be embedded in the control circuits of wind turbines or as a separate device.

In early years, compensation systems was typically designed to achieve a unitary  $\cos \phi$  calculated in a large basis, e.g. from monthly active and reactive energy. This was done by adjusting the set-point  $\cos \phi$  in each PFC to a unitary value.

Nowadays, TSO grid codes impose different reactive compensation strategies. Below, there are examples of reactive requirements in the European countries with more installed wind power:

- In E.ON network (Germany), each wind park with a rated power of <100MW must be able to operate with a power factor from 0.95 inductive to 0.95 capacitive (see Figure 1). The operating point for the reactive exchange is determined by the TSO and the new working point must be attained within a minute [4].
- In REE network (Spain), wind parks specifications for the reactive power ranges are not obligatory, but an incentive or penalty complement depending on the achievement of specified  $\cos \phi$  is applied [5]. The  $\cos \phi$ , and so the incentive payment, was calculated every 60 minutes from the active and reactive energy during this period. They depend on the time of the day as shown in TABLE I.
- In Eltra/Elkraft network (Denmark), for wind parks connected to grid voltages below 100 kV, the reactive power, averaged over 5 minutes, that a wind turbine (including wind turbine transformer) exchanges with a grid must lie within the control band shown in Figure 1 unless the exchanged power is less than 25 kVAr [3].

FACTS (e.g. STATCOM) are usually shown as the only alternative in wind parks formed by fixed speed wind turbines to fulfil the grid code requirements on reactive compensation

or voltage control [6].

In this paper the following alternative is presented; it consists in coordinating the actuation of all the PFC installed in the wind park by means of a central controller [7][8]. In this way, actuation of each PFC can be adjusted in real time and independently in order to achieve a specific wind park  $\cos \varphi$  or a reactive power as close as possible to the objective (see Figure 2). A central controller algorithm with the ability to coordinate the actuation over all capacitor steps must be developed.

A control algorithm for the central controller is proposed in this study. Thanks to simulations, the behaviour of this system is evaluated against simpler solutions.

This scheme is installed at the Sotavento Experimental Wind Park (<http://www.sotaventogalicia.com>) located in Galicia (northwest of Spain) [9]. At present, the algorithm has already been implemented in the Central Controller and it is currently being tested.

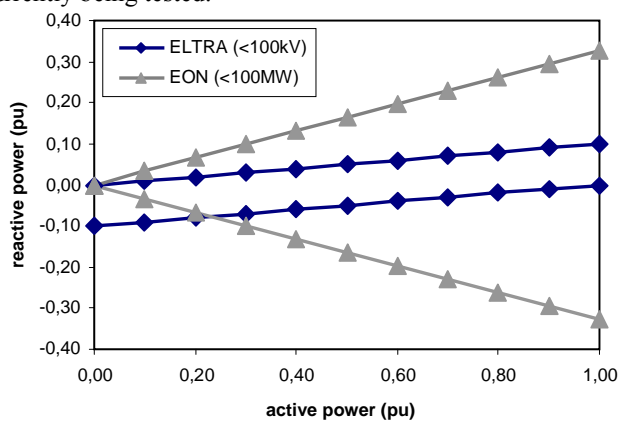

Figure 1 Reactive compensation in ELTRA and EON grid codes

TABLE I INCENTIVE PAYMENT FOR REACTIVE COMPENSATION IN SPANISH WIND PARKS

	$\cos \varphi$	Incentive (%)		
		Peak	Flat	Valley
Inductive	<0,95	-4	-4	8
	<0,96 and $\geq 0,95$	-3	0	6
	<0,97 and $\geq 0,96$	-2	0	4
	<0,98 and $\geq 0,97$	-1	0	2
	<1,00 and $\geq 0,98$	0	2	0
Capacitive	1,00	0	4	0
	<1,00 and $\geq 0,98$	0	2	0
	<0,98 and $\geq 0,97$	2	0	-1
	<0,97 and $\geq 0,96$	4	0	-2
	<0,96 and $\geq 0,95$	6	0	-3
	<0,95	8	-4	-4

## II. THE ALGORITHM FOR THE CENTRAL CONTROLLER

The system shown in Figure 2 is a centralized one, in which actions of all PFC's (located at wind turbines and substation) are coordinated by means of a central controller. The proposed algorithm for this controller works following these steps:

1) In each moment, the reactive power to be generated by the capacitors banks installed in the whole wind park must be calculated. This capacitive reactive power is

obtained from the objective of reactive power or  $\cos \varphi$  for the wind park in each period.

- 2) This amount of reactive must be distributed between the capacitor banks of the substation and the ones of the wind turbines. This must be done by minimizing the number of operations over the substation capacitor banks.
- 3) In this step, the total amount of reactive power that must be generated in all the capacitor banks of all wind turbines is distributed between each wind turbine. An optimization function that takes into account the available capacitors and the active power generated in each wind turbine has been used.
- 4) Finally, the required states of the capacitor steps must be sent to the PFC's.

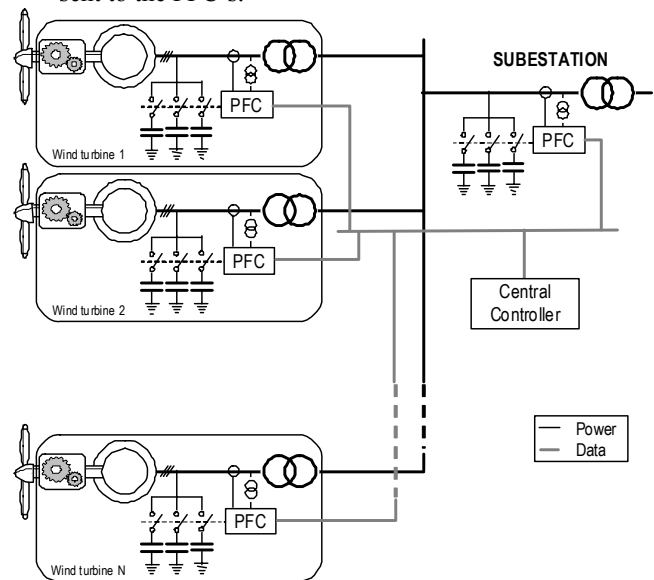

Figure 2 Wind park with a central controller for reactive compensation

### A. Working cycle and capacitive reactive power calculation

The algorithm of the central controller runs in a cyclic way. Every cycle of the algorithm must last a period of time, which is called a segment, less than the time necessary to achieve the objective. For example, in Spain the  $\cos \varphi$  is calculated in periods of 60 minutes, so, the length of the segment must be a fraction of this time. The segment length, or the number of segments in each period, must be optimized so as to get a balance between achievement of the objective,  $\cos \varphi$  or reactive power, and the number of capacitor steps connections. The response of PFC's and the frequency of measurements also have a strong influence on its value.

At the end of each segment, a reactive power error is calculated as the deviation from objective using:

$$\Delta Q^s = Q_{obj} - Q^s \quad (1)$$

where:

- $Q_{obj}$  is the objective reactive power to be generated by the wind park during the current period
- $Q^s$  is the reactive power generated during the segment "s"

- $\Delta Q^{(s)}$  is the reactive power deviation from the objective during the segment “s”

At the end of each segment “s”, the capacitive reactive power to be generated in the following segment is calculated from:

$$Q_{c,obj}^{(s+1)} = \Delta Q^{(s)} + Q_c^{(s)} \quad (2)$$

where:

- $Q_c^{(s)}$  is the capacitive reactive power generated by the wind park capacitors during the segments “s”, calculated from the state of all capacitor steps (in wind turbines and in substation).
- $Q_{c,obj}^{(s+1)}$  is the objective of capacitive reactive power to be generated by the wind park capacitors during the segment “s+1”.

With this compensation strategy, the maximum reactive deviation from the required value in each period is:

$$\sum_{s=1}^{N_s} \Delta Q^{(s)} = \Delta Q^{(1)} - \Delta Q^{(N_s)} \quad (3)$$

where  $N_s$  is the number of segments in each period.

### B. Capacitive reactive power in substation and wind turbines

In the previous paragraph, the amount of capacitive reactive power  $Q_{c,obj}^{(s+1)}$  to be injected by the whole wind park in the segment “s+1” has been calculated. The next step is to allocate this power between the substation and the wind turbines capacitors, so:

$$Q_{c,obj}^{(s+1)} = Q_{Csub}^{(s+1)} + Q_{Cwt}^{(s+1)} \quad (4)$$

where  $Q_{Csub}^{(s+1)}$  is capacitive reactive power to be generated in the substation and  $Q_{Cwt}^{(s+1)}$  is the reactive power to be generated in the set of wind turbines.

Usually, substation capacitors are installed in the MV side, this fact reduces the number of connection operations that can be done in their steps, besides, their discharge can last several minutes. As a consequence, the capacitor steps in wind turbines, normally installed in the LV side, must be used more dynamical in order to fulfil (4).

Taking into account this restriction, the reactive sharing between substation and wind turbines is done through a hysteresis process, as can be seen in Figure 3, where:

- $Q_{Csub,min}$ , is the reactive power for minimum step of substation capacitors battery.
- $0 \times Q_{Csub,min}$ ,  $1 \times Q_{Csub,min}$ ,  $2 \times Q_{Csub,min}$  and  $3 \times Q_{Csub,min}$  represent the achievable reactive power values for two steps with equal nominal power. It must be noted that these achievable values depend on the size of steps installed on substation.
- $Q_{Cwt,max}$  is the total capacitive reactive power that could be generated by connecting all the capacitor steps in all the wind turbines.
- $Q_{CwtL}$  and  $Q_{CwtH}$ , are the low and high limits for the

capacitive reactive power to be generated by the wind turbines.

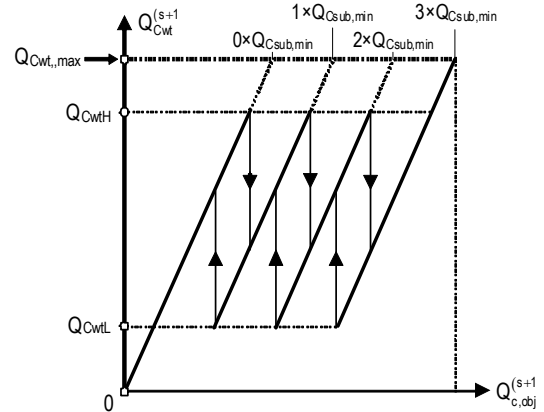

Figure 3 Hysteresis process to allocate the required reactive power between substation and wind turbines

With the aim of getting a solution for the allocation with the hysteresis process shown in Figure 3, the next rules must be followed:

- Operations over the substations capacitor steps are only done when the total wind turbine reactive is out of the limits  $Q_{CwtL}$  and  $Q_{CwtH}$
- When a change in the state of substation steps is necessary, the solution to the new values for substation reactive power  $Q_{Csub}^{(s+1)}$  and total wind turbine reactive power  $Q_{Cwt}^{(s+1)}$  will be as far as possible from the limits  $Q_{CwtL}$  and  $Q_{CwtH}$
- The central controller must estimate the time left to accomplish the complete capacitor discharge. So, only discharged steps will be considered when the solution to (4) is calculated.
- When a solution to the allocation is not found (e.g. when some capacitors are discharging), the closest one is chosen.

### C. Wind turbine reactive allocation

In previous paragraphs, it has been calculated the amount of reactive power  $Q_{Cwt}^{(s+1)}$  to be generated by all the capacitor steps installed in wind turbines. Now, it is necessary to distribute this reactive power between each wind turbine using an optimization algorithm. Dynamic programming has been used in the optimization process, its associated cost function takes into account the number of capacitor steps to be connected or disconnected and the power delivered by the wind turbine [10][11][12]. In this way, the desired reactive power is achieved with a minimum of capacitor steps operations.

#### 1) Discretization and cost function

Once the total capacitive reactive power  $Q_{Cwt}^{(s+1)}$  is calculated, as shown above, the next task is to distribute it between the capacitor steps of each wind turbine.

In a wind turbine, the capacitive reactive power generated depends on the state of the capacitor steps. So, there are  $2^N$  possible step combinations for a wind turbine with  $N$  steps,

although, there are only  $N$  different reactive power values if all the steps have the same size. The number of step combinations exponentially increase with the number of steps, especially if all the capacitors of each wind turbines are treated as a whole set of capacitor steps. In this way, for a certain  $Q_{Cwt}^{(s)}$  value could exist a great deal of step states of wind turbines combinations which generate this reactive power. This makes difficult to calculate a set of optimal step states for the entire wind park. To cope with this problem, an optimization method based on dynamic programming is proposed in the next paragraphs.

In order to decrease the number of operations to calculate an allocation solution, the space of possible values of  $Q_{Cwt}^{(s+1)}$  is discretized. Thus, any value of  $Q_{Cwt}^{(s+1)}$  is corrected with the expression:

$$Q_{Cwt}^{(s+1)} = \text{round} \left\{ \frac{Q_{Cwt}^{(s+1)}}{Q_{\min}} \right\} \times Q_{\min} \quad (5)$$

where  $Q_{\min}$  is a reactive value used to discretizing, it could be the maximum common divider for all the capacitor steps in all wind park.

For each wind turbine “ $i$ ” a vector called  $Q_{Cwt,i}^{(s+1)}$  with  $N_{C_i} + 1$  elements is calculated, where:

$$N_{C_i} \approx \frac{Q_{\text{total},i}}{Q_{\min}} + 1 \quad (6)$$

and  $Q_{\text{total},i}$  is the maximum reactive power that can be generated by the capacitors installed on the wind turbine “ $i$ ”.

Each vector element, from 0 to  $N_{C_i}$ , has associated a reactive power calculated as  $k \times Q_{\min}$ , where  $k$  is the position of the vector element. The value for a  $k$ -element is calculated by means of a cost function, defined below, only if the corresponding capacitive reactive power is achievable with the capacitor steps installed in the wind turbine “ $i$ ”. So, the elements  $Q_{Cwt,i}^{(s+1)}$  are defined as:

$$Q_{Cwt,i}^{(s+1)}(k) = \begin{cases} \Psi_{k,i} & \text{if } \exists j \in \{1, \dots, 2^{N_i}\} \mid \sum_{r=1}^{N_i} E_{i,j}(r) Q_{S_{i,r}} = k Q_{\min} \\ \text{null} & \text{otherwise} \end{cases} \quad (7)$$

where:

- $N_i$  is number of capacitor steps in the wind turbine “ $i$ ”
- $E_{i,j}$  is a  $N_i \times 1$  vector whose elements represent a possible state of the capacitor steps in the wind turbine “ $i$ ”. The “0” value represents a disconnected step, and “1” represents a connected one.
- $Q_{S_{i,r}}$  is the capacitive reactive power for the step “ $r$ ” in the wind turbine “ $i$ ”
- $\Psi_{k,i}$  is a cost function that will be defined below.

The cost function is the value to be optimized and it is defined as:

$$\Psi_{k,i} = \text{NOP}_{\min,k} + 10^{-3} \cdot \left( k \cdot Q_{\min} - T_i \cdot \frac{P_i^{(s)} - P_{Ni}}{P_{Ni}} \right)^2 \quad (8)$$

where:

- $T_i$  is a constant
- $P_{Ni}$  is nominal power for the wind turbine “ $i$ ”
- $P_i^{(s)}$  is the mean power generated by wind turbine “ $i$ ” during the segment “ $s$ ”
- $\text{NOP}_{\min,k}$  represents the minimum step states changes to achieve the reactive  $k \times Q_{\min}$ , thus:

$$\text{NOP}_k = \min \left\{ \text{sum} \left( \text{xor} \left\{ E_i^{(s)}, E_{i,j} \right\} \right) \right\}_{j \in \{1, \dots, 2^{N_i}\}} \quad (9)$$

where  $E_i^{(s)}$  represents the step states at the end of segment “ $s$ ”

The cost function has two terms, as shown in (8). One term is related to the operations number, so, the optimization of this function will guarantee that the number of operations over the capacitor steps will be minimized. The second one is intended to achieve that those wind turbines that are generating more active power can also be the ones generating more capacitive reactive power.

## 2) Optimization process

In previous paragraphs, a set of vectors  $Q_{Cwt,i}^{(s+1)}$  for each wind turbine has been calculated. These vectors will be used for the optimization process that calculates the allocation of the total wind turbine reactive power  $Q_{Cwt}^{(s+1)}$  between all the capacitor steps in wind turbines.

Owing to a dynamic programming method a set of cumulated vectors is created (see Figure 4). The first cumulated vector is equal to  $Q_{Cwt,1}^{(s+1)}$  for the wind turbine “1”, and the next ones are calculated following these steps:

- The elements of the new cumulated vector are calculated from the combination between the no-null elements of previous cumulated vector and the next  $Q_{Cwt,i}^{(s+1)}$  vector. The position in the vector is associated to capacitive reactive power, so, the new element’s position is obtained summing the previous cumulated vector plus the wind turbine vector’s positions.
- The new element’s cost is calculated summing the costs of the elements that generate it.
- The final cost of the new element is the minimum value of the costs calculated in the previous point.
- The final cumulated vector has no-null values related to all the possible capacitive reactive power values that can be obtained by any combination of all capacitor steps installed in wind turbines. The size of this vector can be calculated with:

$$N_c \approx 1 + \sum_{i=1}^{N_{wt}} Q_{\text{total},i} / Q_{\min} \quad (10)$$

The value of each no-null element of the final cumulated vector is the optimum cost for associated reactive power. Hence, for any reactive power value or element in the final vector the related step states in each wind turbine can be calculated, and they will be the ones that optimize the capacitor operation number and the sharing of capacitive reactive power.

As a conclusion, for total wind turbine reactive power value  $Q_{Cwt}^{(s+1)}$  the element ( $k_{sel}$ ) that must be selected in the final vector is:

$$k_{sel} \approx \frac{Q_{Cwt}}{Q_{min}} \quad (11)$$

Then, the step states in each wind turbine that generates the optimum value for this element must be calculated, and the following equation must be fulfilled:

$$Q_{Cwt}^{(s+1)} = \sum_{i=1}^{N_{wt}} Q_{Cwt,i}^{(s+1)} \quad (12)$$

where  $Q_{Cwt,i}^{(s+1)}$  represents the optimum value for the capacitive reactive power to be generated in wind turbine “i”.

Each optimum value  $Q_{Cwt,i}^{(s+1)}$  could have associated more than one step state vector. In the following paragraphs a selection method is presented with the aim of eventually deciding the required state for the steps in each wind turbine.

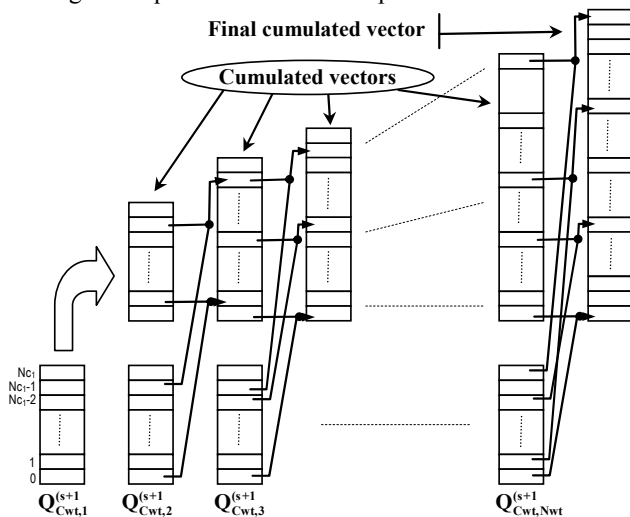

Figure 4 Optimization process

### 3) Optimum step states

The central controller must send the desired step states to each PFC, installed in substation and wind turbines, in order to achieve the required reactive compensation.

In the preceding paragraphs, the capacitive reactive power  $Q_{Csub}^{(s+1)}$  required in the substation during the segment “s+1” and the corresponding reactive capacitive power to be generated in each wind turbine  $Q_{Cwt,i}^{(s+1)}$  have been calculated. The next step is to calculate the states of capacitor steps so as to get the mentioned reactive power.

In the substation the number of capacitor steps is usually low. In this case, the required state for them can be easily calculated, nevertheless, the capacitors discharge time must be respected when deciding the steps that must be connected.

In the case of wind turbine capacitors, since the typical discharge time for LV capacitors is lower than 1 minute, estimation of discharge state could be overcome if the duration of the segment ( $T_s$ ) was large enough.

Lastly, it is necessary to calculate the step states vector for

each wind turbine. As shown in previous paragraphs, an optimum wind turbine reactive power  $Q_{Cwt,i}^{(s+1)}$  could have several step state vectors with the same reactive power. This states are defined as:

$$\{E_{i,1}^{opt}, E_{i,2}^{opt}, \dots\} \quad (13)$$

where:

$$Q_{Cwt,i}^{(s+1)} = \sum_{r=1}^{N_i} E_{i,m}^{opt}(r) Q_{S_{i,r}} \quad (14)$$

The selected step state vector is one that minimizes these values:

- The number of state changes between a step states vector and step states at the end of segment “s”.
- The number of accumulated connection operations, typically PFC’s take account of these values, for the capacitor steps to be connected and/or disconnected.

In order to decide which step state vector is more appropriate, a selection between vectors is done by means of the above mentioned rules.

Thanks to the the selection process depicted above, the accumulated number of connection step operations will be balanced between the capacitor steps of the same size in each wind turbine.

## III. THE SOTAVENTO EXPERIMENTAL WIND PARK

The algorithm depicted in this paper is being implemented at the Sotavento Experimental Wind Park. The project, called Sotavento Galicia S. A. [9], was born in 1997 promoted by the Consellería de Industria e Comercio (Department for Industry and Trade), one of the departments of Xunta de Galicia (local government). Its objective is still to obtain not only economic, but also scientific and technical benefits. Three public institutions are taking part in this project, with a total amount of 51% of its capital.

The Sotavento Experimental Wind Park has installed 24 wind turbines (see TABLE II) with a total power of 17.56 MW and an estimated annual energy production of 38.5 GWh.

TABLE II WIND TURBINES INSTALLED IN THE SOTAVENTO WIND PARK

Wind Turbine Model	N°	Power (kW)	Pitch / Speed
Izar-Bonus 1.3 Mw	1	1300	Variable / Fixed
Made AE - 46	4	660	Fixed / Fixed
Neg Micon NM-750	4	750	Fixed / Fixed
Neg Micon NM-900	1	900	Fixed / Fixed
Ecotecnia 44 - 640	4	640	Fixed / Fixed
Made AE-52	1	800	Variable / Variable
Izar-Bonus MK - IV	4	600	Fixed / Fixed
Gamesa G-47	4	660	Variable / Variable
Made AE - 61	1	1320	Fixed / Fixed

## IV. SIMULATION

The behaviour of the Sotavento Experimental Wind Park with the reactive compensation configuration shown in Figure 2, and the central controller introduced in this article are evaluated through simulation. A wind park model and a PFC model are needed and, therefore, presented in the next paragraphs.

### A. Wind park model

Wind park has been modelled from the measurement data given by the Sotavento experimental wind park. The active and reactive curves for each wind turbines have been calculated from these measurements; the results can be seen in Figure 5.

In addition, the losses in lines and transformer have also been modelled as a function of the power generated by the wind park, as shown in Figure 6.

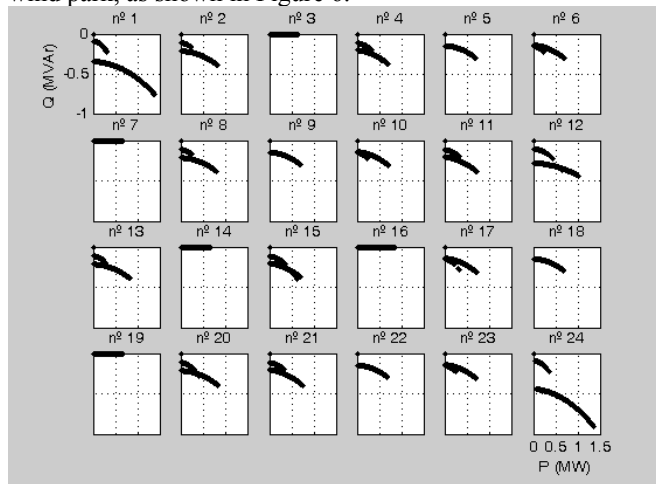

Figure 5 PQ curves from wind turbines

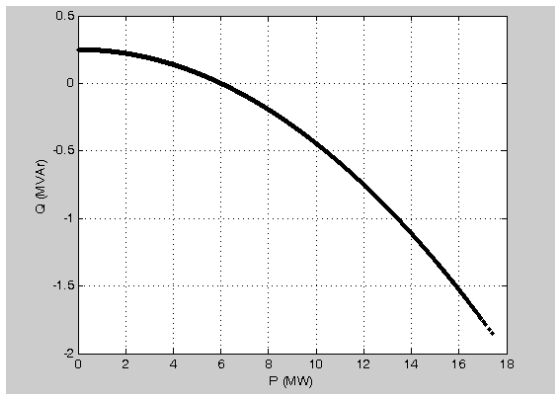

Figure 6 Reactive losses versus the power generated by the wind park

### B. PFC model

In the Sotavento experimental wind park a commercial PFC device has been installed in the substation and in all the wind turbines that will participate in the centralized reactive compensation. A model for this device has been done by means of laboratory tests. The agreement between the measured behaviour and the simulated one when the PFC is installed in a wind turbine can be observed in Figure 7. In this figure, the following values are plotted: power delivered by the wind turbine, the simulated  $\cos \phi$ , the measured  $\cos \phi$  and the  $\cos \phi$  set-point.

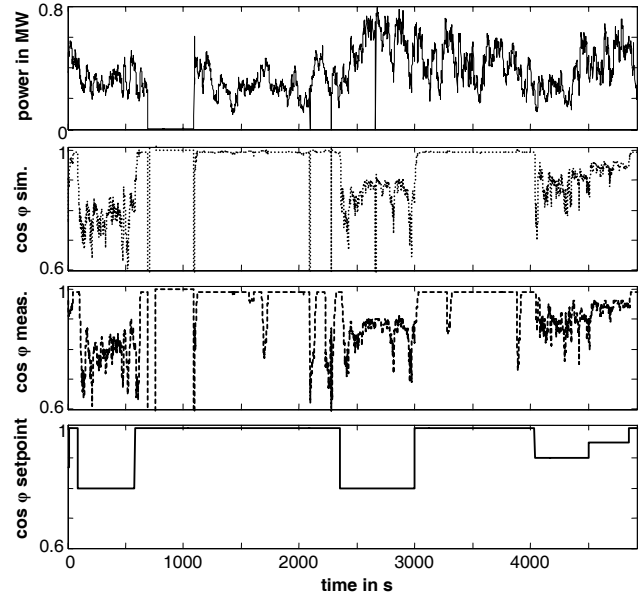

Figure 7 PFC simulation results

## V. RESULTS

The central controller algorithm for the system depicted in Figure 2 has been introduced in previous sections. In order to evaluate the benefits of this centralized configuration, a comparison against a local controlled system is done. In this local scheme, the reactive compensation is locally done with the PFC installed in each wind turbine and in the substation. The  $\cos \phi$  set-point for all PFC's is the same, and it is controlled by a timer, the set-points are adjusted to the maximum payment values shown in TABLE I.

The data for simulation, active and reactive power in substation and wind turbines, has been obtained from 5 days measurements given by the Sotavento experimental wind park. As an example, the wind park power used during the simulation can be seen in Figure 8.

The simulation results for the proposed central system are called Central, and the results for the local controlled system are known as Local; both can be observed from Figure 9 to Figure 14.

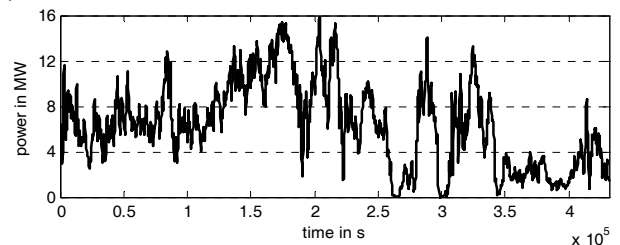

Figure 8 Power generated by the wind park (measured in substation)

For the sake of understanding the results in an easy way, during the simulation the objective  $\cos \phi$  has been considered constant, so, different simulations have been done for flat, valley and peak situations.

The reactive power generated by the wind park during a flat period is shown in Figure 9. The results for the central system are closer to the objective than those for the local system. The

same behaviour can be seen in Figure 10 where the incentive payment and  $\cos \phi$  for each 60 minutes period is shown [5].

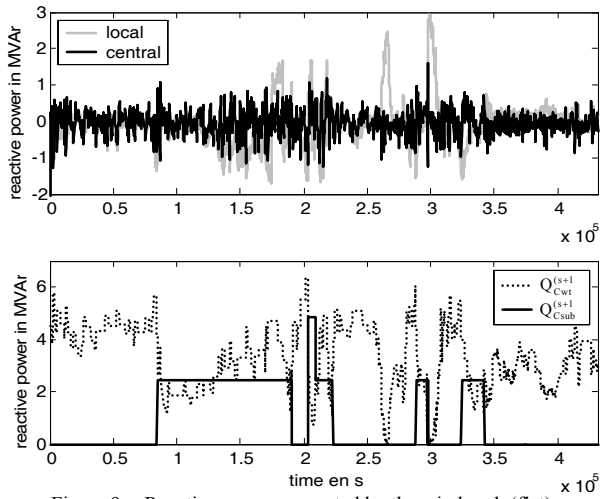

Figure 9 Reactive power generated by the wind park (flat)

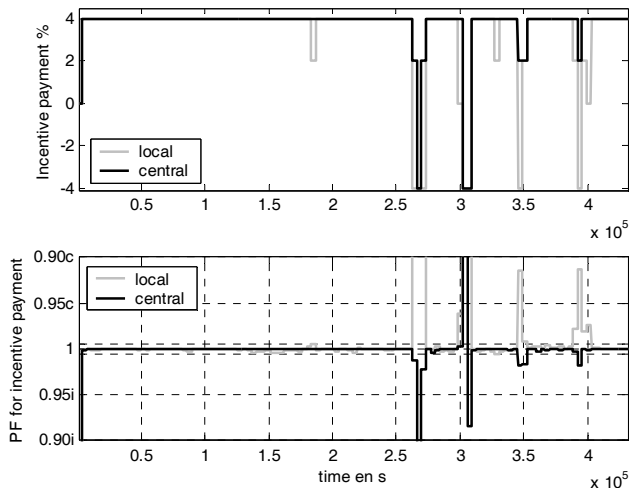

Figure 10 Incentive payment and  $\cos \phi$  for each 60 minutes period (flat)

The results for the capacitive reactive power in the substation and total reactive power for the wind turbines are shown in Figure 9. As can be checked, the capacitors in wind turbines are more dynamically treated than those in substation.

Figure 11, Figure 12 and Figure 13 show active power versus reactive power and the limit for the objective  $\cos \phi$  (see TABLE I). In all the situations (flat, valley and peak), the results for central system are closer to the desired value than those for the local system.

Finally, Figure 14 shows the accumulated connection operation number for each step in a wind turbine whose steps have the same reactive power. The operation number is balanced between all the steps due to the actuation of the central algorithm.

A summary of simulation results is presented in TABLE III, where the total incentive payments during the simulation period and the total number of connection operations for all the steps in the wind park are displayed. As can be seen, the reduction of operation number for the central system is higher than a 70% when compared to the local system. Furthermore, the incentive payment has been increased more than a 3%.

It must be noted that the achievement of a  $\cos \phi$  in low generation situations is influenced by the stops of wind turbines at low wind conditions. Moreover, in peak periods with high generation the amount of installed capacitive power limits the achievable  $\cos \phi$ .

Incentive Payment (%)	Operation Number	Reg.	Period
3,98	5127	Central	Flat
3,86	25578	Local	
7,77	7678	Central	Peak
7,45	34393	Local	
8,00	3434	Central	Valley
7,53	33734	Local	

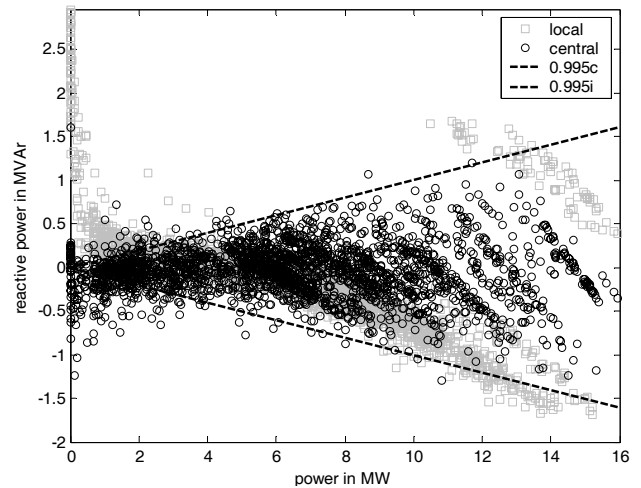

Figure 11 Active power versus reactive power (flat)

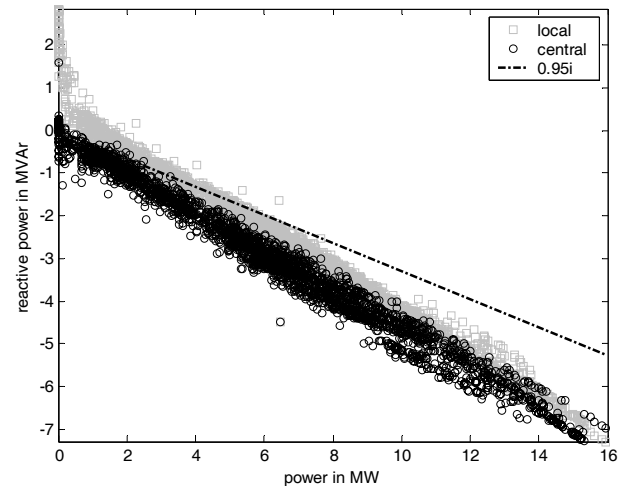

Figure 12 Active power versus reactive power (valley)

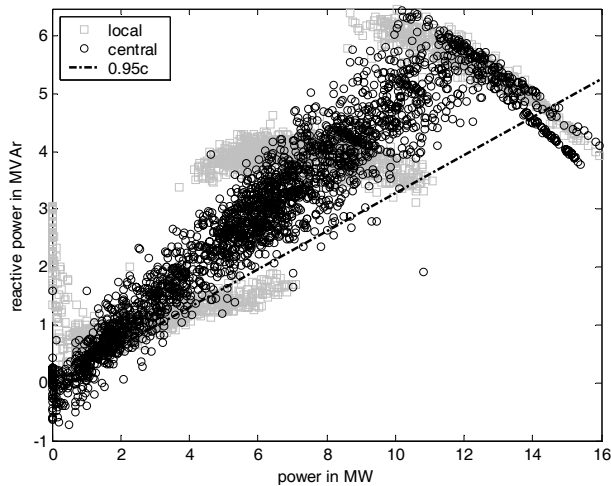

Figure 13 Active power versus reactive power (peak)

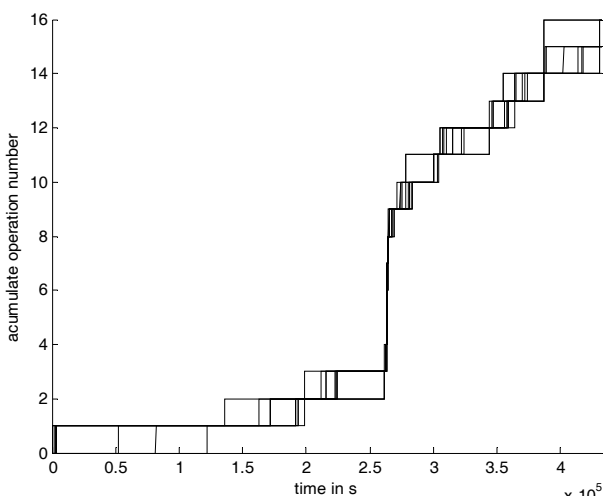

Figure 14 Number of step connection operations in a wind turbine with capacitor steps of the same size.

## VI. CONCLUSIONS

In this study a scheme for reactive compensation in wind parks is depicted. The system is based on the coordination of all capacitor steps in wind turbines and in substation by means of a central controller. All local PFC's continuously receive the desired state for its capacitor steps from the central controller.

The algorithm for the central controller is presented here. Its main objective is to achieve the specific wind park objective,  $\cos \phi$  or reactive power value, with the minimum number of capacitor steps operations. Furthermore, the operations in substation capacitor steps are taken into account with a pre-selection process.

The main conclusions of this article are:

- The behaviour of the central system is compared to a local one by means of simulation.
- Modelling of PFC's and wind park has been done through real measurements and laboratory tests.
- With the central controller algorithm, the achievement of a specific  $\cos \phi$  is higher than that achieved with a local scheme. Besides, the number of operations over the

capacitor steps is highly reduced.

- The number of operations in substation has been specially reduced with the central system.
- The accumulated steps operation in a wind turbine has been balanced so that capacitor steps of same size have a similar number of operations.

The central scheme for reactive compensation as shown in Figure 2 has already been implemented at the Sotavento Experimental Wind Park; at this time, the algorithm for the central controller is currently being tested.

## ACKNOWLEDGMENT

The authors would like to thank the personnel of Sotavento Experimental Wind Park for their contribution and help with field experience, and for their accessibility to the measurement data.

## REFERENCES

- [1] A.F. Zobaa1, and M. Jovanovic; "A comprehensive overview on reactive power compensation technologies for wind power applications", *12th International Power Electronics and Motion Control Conference*, pp. 1848-1852, May 2006
- [2] "Wind farm power station grid code provisions", ESB National Grid, July 2004, <http://www.eirgrid.com>
- [3] "Wind Turbines Connected to Grids with Voltages Below 100 kV—Technical Regulations for the Properties and the Control of Wind Turbines, Energinet.dk, Technical Regulations TF 3.2.6", Denmark, 41 p., Nov. 2004. [Online]. Available: <http://www.energinet.dk>
- [4] "Energiewirtschaftliche Planung für die Netzintegration von Windenergie in Deutschland an Land und Offshore bis zum Jahr 2020. Konzept für eine stufenweise Entwicklung des Stromnetzes in Deutschland zur Anbindung und Integration von Windkraftanlagen Onshore und Offshore unter Berücksichtigung der Erzeugung- und Kraftwerkentwicklung sowie der erforderlichen Regelleistung. Konsortium", DEWI/E.ON Netz/EWI/RWE Transportnetz Strom/VE Transmission, Endbericht, Köln, Germany, Feb. 2005. [Online]. Available: <http://www.deutsche-energie-agentur.de>.
- [5] Spanish Royal Decree on Transmission, Distribution, Retail and Supply of the Electric Energy; "RD 661/2007, de 25 de mayo, por el que se regula la actividad de producción de energía eléctrica en régimen especial" (available at <http://www.cne.es>)
- [6] N. Dizdarevic, M. Majstrovic; "FACTS-based reactive power compensation of wind energy conversion system", *Power Tech Conference Proceedings, 2003 IEEE Bologna*, vol. 2, June 2003
- [7] F.C. Lu, H.C. Kuo; "Management of reactive power on a radial M.V. network by using an expert system", *Electrotechnical Conference, 1996. MELECON '96., 8th Mediterranean*, vol. 3, No 6, pp. 1603-1606, May 1996
- [8] R.G. de Almeida et al; "Optimum generation control in wind parks when carrying out system operator requests", *IEEE transactions on power systems*, vol. 21, No 2, pp. 718-725, May 2006
- [9] J. López, A. Dorado, J. Álvarez, A. Feijóo, C. Carrillo, J. Cidrás, E. Menéndez; "The Sotavento experimental wind park", *Global Windpower Conference, Paris, April 2002*
- [10] F.C. Lu, H.C. Kuo; "Dispatch capacitors on distribution system using dynamic programming", *IEE Proc. C*, vol. 140, No 6, pp. 433-438, November 1993
- [11] F.C. Lu, Y.Y. Hsu; "Reactive power/voltage control in a distribution substation using dynamic programming", *IEEE Proc-Gener. Transm. Distrib.*, vol. 142, No 6, pp. 639-645, November 1995
- [12] E- Diaz-Dorado, C. Carrillo, J. Cidrás; "Coordinated Reactive Compensation in a Wind Park"; Proc. 9th Int. Conference EPQU'07, Barcelona, 9-11-October-2007

**E. Díaz-Dorado** received his Ph.D. degree in electrical engineering from the University of Vigo (Spain) in 1999. He is a professor in the Electric Engineering Department at University of Vigo (Spain) and he is interested in the estimation and the planning of power systems, quality power and wind energy systems.

**C. Carrillo** received his degree in electrical engineering from the Universidade de Vigo (Spain) in 1992 and his Ph.D. degree in electrical engineering in 2001. He is a professor in the Departamento de Enxeñaría Eléctrica. His main fields of research are quality power and wind energy systems.

**J. Cidras (1957)** received his degree in electrical engineering from the Universidad de Las Palmas de G.C. (Spain). He obtained a Ph.D. in electrical engineering from the Universidade de Santiago (Spain) in 1987. He is a professor in the Departamento de Enxeñaría Eléctrica of the Universidade de Vigo (Spain), and leads some investigation projects on wind energy, photovoltaic and planning of power systems. He is a member of IEEE.