

Verbs of cognition in Spanish: Constructional schemas and reference points

José M^a García-Miguel & Susana Comesaña

Abstract

This paper examines the interaction between verb meaning and construction meaning using as an example a group of so-called 'cognition' or 'propositional attitude' verbs in Spanish (*saber, creer, pensar, considerar, juzgar, estimar, imaginar, suponer*, etc). Such a set of verbs share a number of semantic and conceptual features that partly condition the constructional schemas in which they can appear. Our point of departure agrees with Construction Grammar (Goldberg 1995) in the assumption that, on the one hand, verbs involve frame-semantic meanings, and on the other hand, constructions have cognitive abstract meaning partly independent of verbs instantiating them. Thereby, the final meaning is the result of the interaction between verb meaning and construction meaning. The frame activated by cognition verbs involves a conceptualizer and a conceptual content, but each construction proposes a specific construal of the scene. The more relevant differences have to do with the relative prominence of entities that can serve as reference-point in the mental access path from the conceptualizer to the propositional content

Keywords: Reference point, cognition verbs, Construction Grammar

1. Introduction

The interaction between verb meaning and construction meaning has been largely defended by Goldberg (1995), who argues for the relative independence and compatibility between verb meaning and construction meaning, that is, the interaction of the meaning of lexical items with the properties and meaning of constructions.

The verb meaning entails a rich frame-semantics meaning involving interacting participant entities. Verbs from the same class/group share most elements of their conceptual base (Lakoff's ICM) and differ about the profile they impose on that base and about how they elaborate the base.

The meaning of abstract constructional schemas (for ex.: ditransitive construction) must be necessarily more schematic than verb meaning,

since it must fit many verbs from different domains. On the other hand, constructional schemas provide alternate conceptualizations compatible with the same verb. Explicit and implicit participants are determined by the integration of verb meaning and construction meaning, showing differences in construal, specifically differences in attention and focusing. In general, obligatory verb arguments of included explicit in the schema; but construal allows that necessary elements in frame evoked by the verb do not receive expression in specific constructions, and that secondary or not essential elements in evoked frame could be construed as central participants.

This paper is based on corpus observations, namely on ADESSE (“Alternancias de Diátesis y Esquemas Sintáctico-Semánticos del Español”), a database for the empirical study of the interaction between verb meaning and construction meaning, containing both syntactic and semantic features about Spanish verbs¹. It aims to include a list of constructional schemas admitted by every verb in the corpus², a general semantic classification of verb senses, the identity of participant roles in the evoked frame, and frequencies in the corpus for each verb and constructional alternatives.

Within this ADESSE data base, 98 Spanish verbs are provisionally classified as cognition verbs. Table 1 shows the basic construction for those cognition verbs

Table 1. Syntactic constructional schemas common with cognition verbs (and frequency in BDS/ADESSE)

Transitive	SUB - DO	9879
Complex transitive	SUB - DO – ObjComp	295
Ditransitive	SUB - DO – IO	161
Oblique Transitive	SUB - DO – Oblique(de/sobre, ...)	259
Intransitive	SUB	1570
Oblique intransitive	SUB - Oblique(en/con de, ...)	873

Along with the canonical transitive construction, other constructional schemas are also common with cognition verbs in Spanish. Some of them include an additional constituent whose motivation will be explained below. However, intransitive constructions will not be considered in the present work.

1. This research is funded by Spanish Ministry of Science and Technology (BFF2002-01197), partly using EU FEDER funds, and by the Xunta de Galicia (PGIDIT03PXIC30201PN)
2. The syntactic analysis comes from BDS, a Syntactic Database of contemporary Spanish, containing syntactic function, and syntactic category of the core arguments of 159.000 clauses from a corpus which amounts about 1,5 million words. The references of the quoted examples correspond to this corpus (<http://www.bds.usc.es/>).

2. Verbs of cognition: knowing and believing

Verbs of cognition designate mental processes, in the sense of Halliday (1985)³. As mental processes, they involve potentially a Senser or Cognizer (subject of knowing or believing) and an object of knowledge or belief of this mental process (a 'Phenomenon'). So usually the participants in a clause of mental process are a human participant who knows, thinks, feels, etc and a 3rd order entity, construed as a participant by projection, typically in the form of a complement clause (Halliday 1985: 115-119).

Achard (1998) has studied within a Cognitive Linguistics framework a set of French verbs (perception, declaration, volition and emotion/ reaction verbs) also construed with complement clause, in what he labels the “conceptualizing subject construction”, depicted in figure 1. The subject of main clause has a role of conceptualizer with regard to complement clause, more or less as the speaker conceptualizes the whole scene.

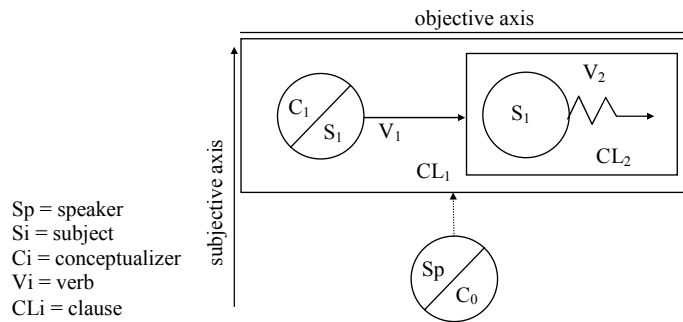

Figure 1. Complementation in conceptual terms (Achard 1998: 65)

For example:

- (1) *María cree que Juan llegó ayer*
 C1/S1 V1 S2 V2

Within the conceptualizing subject construction, knowing and believing verbs specifically are qualified as ‘propositional attitude verbs’. These are not factive predicates that specify the subject attitude with respect to possible event designated by complement clause. They state the

3. Mental processes are “processes of feeling, thinking and seeing” (Halliday 1985: 117).

level of certainty or uncertainty towards the content of the complement structure (Achard 1998: 178).

In terms of mental spaces theory (Fauconnier 1995, 1997, 1998), beliefs are typical examples of mental space builders. Cognition verbs are mechanisms which speaker uses to set up a subordinate mental space. For example (Fauconnier 1998: 253-257), in *Max thought the winner received \$ 100*, we may easily distinguish a base space ('reality') containing Max, and another space containing "what Max thinks", namely that someone *received \$100*. The NP *the winner* is a description, accessing a role or a value either in the base space (the speaker considers someone the winner, independently of Max thoughts) or in the projected space (Max considers someone the winner, independently of reality and speaker thoughts). Then, a complement clause typically represents a subordinate mental space, which may be related in several manners to the base space ('reality', as construed by the speaker and/or cognizer).

The process of accessing a secondary mental space can be also understood in terms of *reference-points*, a concept elaborated by Langacker (1991, 1993):

The world is conceived as being populated by countless objects of diverse character. These objects vary greatly in their salience to a given observer (...) Salient objects serve as reference points: if the viewer knows that a non-salient object lies near a salient one, he can find it by directing his attention to the latter searching in its vicinity (...) the **target**, i.e. the object that the viewer seeks to locate. (...) Each reference point anchors a region that will be called its **dominion**. (Langacker 1991: 170)

The notion of reference-point is relevant to a large set of linguistic phenomena such as the sanction of definite articles, metonymy, possessive constructions, *topic* constructions and grammatical relations. In most cases, reference point and target use to be nominals ('things'), but a reference point relationship between for example a thing and a proposition is also possible (Langacker 2000: 26), and that is what happens with cognition verbs. Moreover, in cognition verb constructions there is a natural reference point chain involving the main elements of figure 1 (C0 → C1/S1 → S2 → CL2/V2): the speaker (C0) seeks the projected mental space in the dominion of the conceptualizer/subject (C1/S1) of the cognition verb, and the subject (S2) of the complement clause, as relational figure (*trajector*), serves as a reference point to the process as a whole included in the projected mental space. (cf. Langacker 2000: 36). As we will see, this reference point chain is maintained, in general terms, across the different syntactic schemas of cognition verbs.

3. Transitive construction: SUBJ-DO

The “conceptualizing subject construction” of figure 1 represents the essential aspects of the frame evoked by any cognition verb. Such a frame is elaborated in different manners by particular verbs and constructions. As table 1 shows, the basic construction for cognition verbs is the transitive: 9878 examples of the transitive construction are registered in BDS/ADESSE with 69 verbs of cognition. The more frequent verbs are *saber* ‘know’, *creer* ‘believe’, *pensar* ‘think’, *recordar* ‘remember’, *entender* ‘understand’, *reconocer* ‘recognize’, *olvidar* ‘forget’, etc.

A canonical transitive event implies an asymmetric energetic interaction between two participants. In mental processes, there is no energetic interaction between concrete individuals, but there is a unidirectional asymmetric relation between a human Cognizer as Subject and a Propositional content as Object.

Table 2. Transitive constructional schema

Cognition	<Cognizer	Content>
PRED	SUBJ	DIRECT OBJECT
V	NP-Human	clause / NP

Therefore, the transitive construction profiles the asymmetric relation between Cognizer and propositional Content, and selects the human cognizer as primary figure (trajector of the profiled relation)

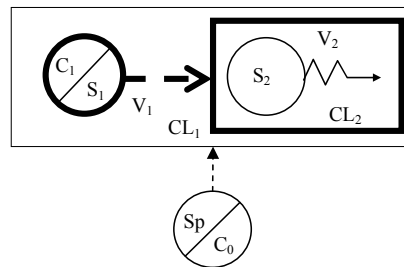

Figure 2. Profiling in the transitive constructional schema S – V – D (clause)

The more relevant variants in the instantiation of this high-level abstract schema depend on the nature of the object: complement clause in indicative, infinitive clause, noun phrase, etc... Nevertheless, the most frequent subschema for cognition verbs (4893 + 1041 examples in ADESSE) profiles a mental relation between a human subject and propositional content expressed by a clause or referred to by a clitic pronoun.

- (2) a. *Tú pensarás que estoy loco* (SONRISA: 234) [finite clause]
 ‘You are probably thinking that I am mad’
 b. *Pensaba visitar a Gloria Valle* (SUR: 45) [infinite clause]
 ‘He planned to visit Gloria Valle’
 c. *Ya pensaremos alguna solución* (CAIMAN: 38) [noun phrase]
 ‘We will think later about a solution’

Some alternatives depend also on the nature of the subject. Figure 1 shows an ‘objective’ construal where the speaker observes the scene off-stage. However, as shown in table 3 the most frequent case with verbs of cognition is a 1st person subject, that is, C1 (Subject) equates with C0 (Speaker) so that the speaker is also the conceptualizer of the projected mental space, and the distance along the subjective axis of figure 1 is reduced.⁴

Table 3. Subject in SUB DO construction (active voice)

Nº Pers	N	%
1 ^a sg.	4281	43,4%
2 ^a sg.	1518	15,4%
3 ^a sg.	4079	41,2%
Total	9878	100 %

Comentario: Esto tiene una base conceptual/procesual/funcional. Uno sabe más sobre sus propios pensamientos, opiniones, creencias que sobre las de los demás

A similar issue concerns the distance between C1 and CL2 along the objective axis, and is related to the choice between a finite clause and an infinitive construction. This choice depends, in the first place, on the coreferentiality of subject. An infinitival complement is only possible when the subject of the main verb and the subject of the subordinate verb are coreferential. A finite complement is not affected by such restriction

- (3) a. *Mis amigos los vascos creen pertenecer a su país* (JOVENES: 135)
 Literal: ‘My Basque friends think to belong to their country’
 b. *Creo que <Madrid> es una ciudad muy incómoda* (MADRID: 73)
 ‘I think that it is a very inconvenient town’
 c. *Creo que no volveré más a Gijón* (MADRID: 26)
 ‘I think that I will not come back to Gijón’

According to Achard (1998: 173-215), this restriction is related to differences in viewing arrangement along the objective axis. The finite complement signals an objective construal of the scene, that is, an “optimal viewing arrangement” [OVA] which maximizes the asymmetry between the conceptualizer and the object of conceptualization

⁴ This fact has a clear basis: one knows better his own beliefs.

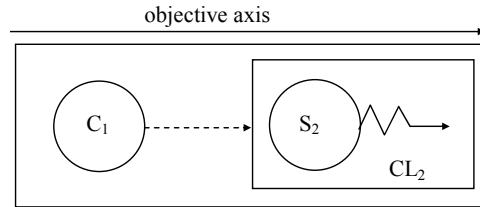

Figure 3. Finite clauses: “OVA” (slightly simplified from Achard 1998: 188)

On the contrary, an infinitival complement signals a subjective construal from the vantage point of S₂, that is, an “egocentric viewing arrangement” [EVA] that blurs the asymmetry between subject and object of conceptualization, since the activity profiled by the subordinate verb is construed from the vantage point of someone engaged in it (and that is why S₁ and S₂ must be coreferential)

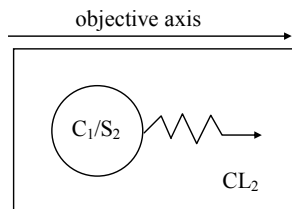

Figure 4. Infinitival complements: EVA (Achard 1998: 189)

The conceptual distance between cognizer and subject of CL₂ depends primarily on the meaning of the main verb. Achard notes that perception verbs (which “maximize the subject/object asymmetry”) are not construed with infinitive, whereas the infinitive is obligatory with volition verbs in case of coreference between S₁ and S₂. Cognition verbs admit both possibilities, but not all of them. In BDS/ADESSE most cognition verbs are registered either with finite complement or with infinitival complement: *saber*, *decidir*, *creer*, *pensar*, *recordar*, *aceptar*, *acordar*, *resolver*, *olvidar*, *reconocer*, etc. Nevertheless, they show clear differences in meaning

- (4) a. *Y ya sé dar volteretas.* (CAIMAN: 41)
 ‘And I already know (how) to do somersaults’

- b. # *Ya sé que doy volteretas*
 ‘I already know that I do somersaults’
- (5) a. *Yo no me pienso casar.* (OCHENTA: 67)
 ‘I don’t think to get married’
- b. # *Yo no pienso que me voy a casar.*
 ‘I don’t think that I’m going to get married’

The infinitival construction gives the main verb a meaning closer to that of modals and dispositive verbs. The finite clause distances and objectifies the propositional content.

On the other hand, many cognition verbs are never registered with infinitival complement in BDS/ADESSE: *comprender, considerar, entender, sospechar, estimar, opinar, intuir, reflexionar, juzgar, etc*

- (6) a. *Comprendió que no tenía coraje para formular tales embustes*
 (HISTORIAS: 62)
 ‘He understood that he didn’t have courage to make such lies’
- b. **Comprendió no tener coraje para formular tales embustes*

The lexical meaning of this second group of verbs maximizes the conceptual distance between C1 and propositional content, as if it was something perceived off-stage. Therefore the construction is coherent with that distance and objectification of the propositional content.

4. Complex transitive construction: SUBJ-DO-OC

The main syntactic alternative to the transitive constructional schema with verbs of cognition is what we will label as ‘complex transitive construction’. In this construction, the Cognizer remains as Subject, but the Conceptualized Content is split into two constituents: a Direct Object noun phrase (or pronominal clitic) and a predicative object complement, usually an adjective phrase (or, also, a nominal phrase with *como* ‘as’).

Table 4. Complex transitive construction with verbs of cognition

Cognition	<Cognizer		>Content>	
PRED	SUBJ	DIRECT OBJECT	OBJECT	PRED COMPLEMENT
V	NP	NP	Adjective Phrase	
	Trajector	Landmark		

The complex transitive construction [CTC] is exemplified in (7a), whereas (7b) exemplifies the fact that the CTC can be usually paraphrased by a canonical transitive construction with a complement clause

- (7) a. *Papá me cree muerta* (CAIMAN: 53)
 ‘Dad believes me dead’
 b. *Papá cree que estoy muerta*
 ‘Dad believes that I am dead’

In BDS/ADESSE there are 295 examples of CTC with 20 different verbs of cognition. The most frequent verbs are *considerar, creer, imaginar, estimar, entender, juzgar*.

The CTC in Spanish is in some respects similar to English “raising” constructions. In these constructions, the “semantic” subject of a non finite subordinate clause is the object of the main verb, although they differ syntactically and semantically from their finite counterparts (Postal 1974, Langacker 1995): With perception and cognition verbs, “raising” constructions are used for judgments based on more direct evidence. For example, (8c) is used when I am actually seated on the chair

- (8) a. *I find that this chair is uncomfortable.*
 b. *I find this chair to be uncomfortable.*
 c. *I find this chair uncomfortable.*

According to Langacker (1995), raising constructions construe the scene giving prominence to the “logical” subject of the infinitive by assigning it the status of primary landmark, and profiling the connection between subject and object. The relation between subject and object is not due to direct interaction between them, but is entirely mediated by the infinitival process. The raised object stands metonymically for the subordinated process, and it acts as *reference point* with respect to the infinitival complement. That is, it is the construal of the scene indicates that C1 establishes mental contact with S1, and it is through it that he accesses the process represented by the infinitive V2

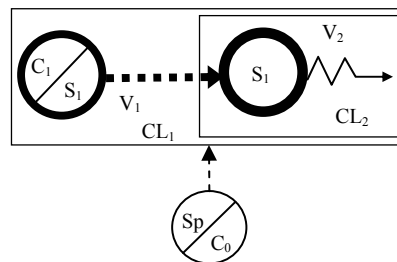

Figure 5. Profiling in raising constructions (NP-V-NP-Infinitive)

Nevertheless, there are important differences between the finite complement clause construction in English and the complex transitive construction in Spanish. First of all, in Spanish the ‘raised’ Object NP cannot combine with infinitives and gerunds.

- (9) a. *Todos creyeron que había besado a Ana.*
‘Everybody believed that he had kissed Ann.’
b. **Todos lo creyeron haber besado a Ana.*
‘Everybody believed him to have kissed Ann.’

Rodríguez Espiñeira (2002) notes that the complex transitive construction lacks the propositional status of finite complement clauses, and in many cases, there is not any possibility of using it as an alternative. According to Rodríguez Espiñeira, the non-propositional status of the complement of the complex transitive construction is reflected in the fact that aspectual, modal and negative expressions are restricted; and the fact that the complex transitive constructions cannot be used as an alternative to dynamic, identifying predications, which serve as a subjective characterization or assessment of the object.

- (10) a. *No creían que fuera yo el fotografiado.* (LABERINTO: 114)
‘They didn’t believe that I was the photographed’
b. **No me creían el fotografiado.*
‘They didn’t believe me (to be) the photographed’

Therefore, the choice between a finite clause construction and a complex transitive construction is limited to non-dynamic, non-identifying relation. But, even when there is the choice between both constructions as in (7), there is no identity of meaning, but a different construal, because the complex transitive construction gives primary prominence (besides the cognizer-subject) to the object NP, which serves as a reference point in the access path to its assessment by means of a predicative adjective.

The prominence of the Object-NP as primary landmark and reference point is akin to two salient properties of this construction, the high topicality of the DO and the mental space where each element is interpreted.

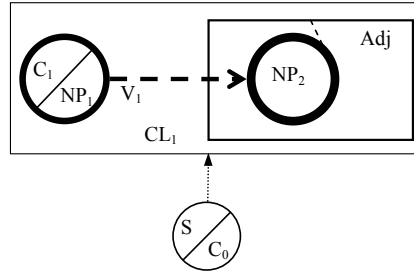

Figure 6. Profiling in complex transitive constructions

The high topicality of the DO in complex transitive construction is corroborated by frequency distribution in our corpus: the DO is usually not clausal (90,2%), definite (87,7%), and in many cases represented only by a pronominal clitic (35,6% of the total cases). So, DO position is occupied by highly accessible referents, already established in the ongoing discourse and in the current mental space. Once established, they can serve as reference point for a concurrent assessment/evaluation by the cognizer/subject of the main verb. This assessment is expressed by the predicative complement.

On the other hand, elements of a finite complement clause are interpreted as part of a subordinate (belief) mental space, and the complement clause designates a proposition whose truth value can be discussed. On the contrary, with complex transitive constructions, the DO-NP is interpreted as part of the base mental space and the predicative characterizes this referent, but it does not get propositional status. So, there is no truth value to be discussed

- (11) a. *Considera que Ana es una asesina, y seguramente no se equivoca.*
 ‘He considers that Ana is a killer, and probably he’s not mistaken’
 b. *La considera una asesina (*y seguramente no se equivoca).*
 ‘He considers her a killer (*and probably he’s not mistaken)’

Moreover, a complement clause within the transitive construction allows existential predications introducing new referents (even referents unreal in the base mental space), whereas in a complex transitive construction such referents should become definite and established in the base mental space.

- (12) a. *La sala le levanta el procesamiento por considerar que no hay pruebas para considerarlo sospechoso.* (1VOZ: 25)

‘The court lift him the trial by considering that there aren’t proofs
for consider him under suspicion’

b. #*Consideran inexistentes las pruebas*

‘They consider nonexistent the proofs’

Summing up this section, we have seen that cognition verbs represent a scene where a cognizer establishes mental contact with a propositional content. This contact with the targeted content can be established through a reference point. The complex transitive construction emphasizes this reference-point as primary landmark raising it to the object position. This object is located in the base mental space along with the cognizer and is typically a definite noun phrase or a pronominal clitic, indexing referents highly accessible in discourse.

5. Ditransitive construction: SUBJ-DO-IO

Besides the transitive construction (with a complement clause) and the ‘complex transitive construction’, in BDS/ADESSE there are 161 examples of 25 verbs of cognition registered in the ditransitive constructional schema (SUBJ - DO - IO). None of them counts among the most frequent verbs in the ditransitive construction in Spanish. The more frequent verbs in this construction are *dar* ‘give’, *decir* ‘tell, say’, *hacer* ‘make’, *poner* ‘put’, and so on. The semantic domains in these cases are other than cognition, they are verbs of transfer (*dar*), communication (*decir, preguntar*), spatial transfer (*poner, traer*), causative and permissive (*enseñar, permitir*), intended transfer to beneficiary (*hacer*).

Like in English, the central sense of the ditransitive construction in Spanish is that of “agent successfully causes recipient to receive patient” (Goldberg 1995: 38), that is, the transfer meaning associated with giving verbs.

Table 5. Ditransitive constructional schema (transfer prototype)

Transfer	<Agent	Patient	Receiver>
PRED	SUBJ	DO	IO

Maldonado (2002) takes also the transfer meaning as prototypical for ditransitive constructions and indirect objects in Spanish, as represented in figure 7.

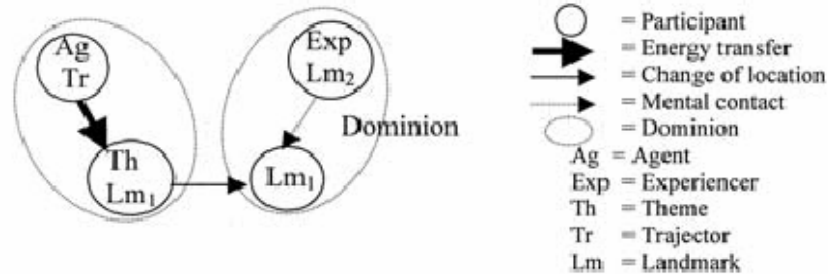

Figure 7. Transfer prototype: *dar, decir* (Maldonado 2002: 9 and 55)

But, developing ideas from Langacker (1991, 1993), Maldonado makes the observation that “the transfer construal implies that the theme ends in the dominion of the experiencer and becomes available for interaction. Thus, the experiencer must also be characterized as a prominent participant that functions as a reference point from which to locate a less prominent entity found in her/his dominion.” (Maldonado 2002: 10)

There are diverse motivations for the presence of IO with cognition verbs; but all of them rely on a metaphorical extension of the transfer construction and/or the communication schema. The more frequent meaning is the causative. Verbs like *recordar* ‘remind’ and *evocar* ‘evoke’ are lexical causatives of (mono)transitive verbs of cognition like *recordar* ‘remember’ or *pensar* ‘think about’

- (13) *La palabra “gitano” me evocaba sufrimientos y peligros* (SUR: 67)
 ‘The word “gypsy” evoked me sufferings and dangers’

Kemmer & Verhagen (1994: 116) argue that (periphrastic and non periphrastic) causative structures are “built up from simpler structural conceptual units, in the sense that they relate (non-derivationally) to more basic clause types”. In particular, the causatives of transitive verbs (TC clauses) are based on simple three-participant clauses. The actual correspondences for verbs of cognition are given in table 6.

Table 6. Correspondence between prototypical ditransitive clauses and causative clauses with cognition verbs (inspired from Kemmer & Verhagen 1994: 126)

3-Participant Clause	Agent	Dative/Receiver	Patient	V ₃
Causative Cognition Verb	Causer	Causee/Cognizer	Content	Vcog-caus

Besides the CAUSATION AS TRANSFER metaphor, that motivates the correspondences between roles for any causative, some ditransitive cog-

dition verbs are also construed on the model of communication verbs. The ditransitive construction gives the verb *recordar* in (14) a causative sense (~‘she made him remember’) and at the same time a communication sense (~‘she said that to him’)

- (14) *Le recordé que era lunes.* (CRONICA: 15)
‘I reminded him that it was Monday.’

The communication frame for ditransitive clauses is also acting as a model in (15), but in this example and in (16), we are using a new metaphor, COGNITION AS TRANSFER, where the IO acts as final possessor or beneficiary of the beliefs of the main subject

- (15) *Pensé en marcharme, te lo reconozco.* (SONRISA: 236)
‘I think of going away, I admit that to you.’
(16) *<A nuestras vecinas> les imaginamos secretariados o escuelas de párvulos en Detroit.* (GLENDA: 31)
‘<Our neighbors,> we imagine secretariats or infant schools in Detroit for them.’

Finally, a third group uses a partially different correspondence, with cognition as inverted transfer (acquisition), where the IO maps with an initial possessor, from which one acquires his beliefs (compare with *comprarle algo a alguien* ‘to buy something from someone’)

- (17) *No es fácil creer esto a un hombre como tú.* (COARTADA: 62)
‘It’s unlikely to believe that from a man like you.’

At this point, we have moved a bit further away from the transfer prototype, as far as this prototype evokes a literal or metaphoric path toward the indirect object. However, the notion of reference point provides a more unified account of the main variants. According to Maldonado, the indirect object functions as a reference point from which to locate the direct object. We may reduce the relevant aspects of figure 7 to the representation of figure 8

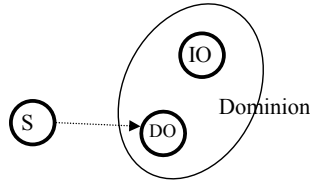

Figure 8. Basic image-schema for the ditransitive constructional schema

With verbs of cognition in the ditransitive schema, the IO dominion corresponds to a virtual area in which a cognizer mentally interacts with a conceptual content, in such a way that he intends to put such content into the IO dominion (as in [14], ...) or he acquires some propositional content within the IO dominion (as in [17]). The distinctive property of the ditransitive construction is that it places both reference point (the IO) and target (the DO) as central participants in the conceptualization of the scene.

6. Oblique transitive construction: SUBJ-DO-OBL

The last construction we will comment on is the “oblique transitive construction”, which adds an oblique complement to subject and object. This construction has in general the characteristics of the transitive construction. But the construction includes an Oblique complement (with the preposition *de*, *sobre* or similar) equivalent to a topic that specifies a reference dominion which restricts the propositions acceptable in that discourse context.

Table 7. Oblique transitive construction with cognition verbs

Cognition	<Cognizer	Content>	Reference
PRED	SUBJ	DIRECT OBJECT	OBLIQUE
V	NP	NP	PrepP (<i>de / sobre / acerca de</i>)
	TR	LM	

The most frequent verbs registered in ADESSE with this structure are *saber* ‘know’, *opinar* ‘be of the opinion that’ and *pensar* ‘think’. The construction is used above all in interrogative clauses, proposing a topic for the ongoing dialogue:

- (18) *¿Y sobre el piso qué opinas?* (MADRID: 72)
 ‘And about the flat, what is your opinion?’
- (19) *-¿Y qué sabe el Papa de sexo?* (SONRISA: 242)
 ‘And what does the Pope know about sex?’

When the direct object is a question-word, the majority of the examples with such verbs are accompanied by an oblique complement setting the discourse topic that is expected to be elaborated in the answer to the question:

Table 8. Interrogatives as DO with *pensar*, *saber* and *opinar*:

Construction	N	%	Example
SUB DO	44	37,6%	<i>¿Qué piensas?</i>
SUB DO OBL(<i>de/sobre</i>)	73	62,4%	<i>¿Qué piensas de/sobre eso?</i>
TOTAL	117		

The table 9 gives the different types of object registered in the oblique transitive construction. The most frequent alternatives imply a very low elaboration of the object, a very schematic meaning representing the content of the process of cognition

Table 9. SUB DO OBL(*de/sobre*) with the verbs *saber*, *pensar* and *opinar*:

DO	%	N	Example
Interrogative (DO = <i>qué</i>)	18,7%	28	<i>¿qué piensas/sabes de eso?</i>
Quantifier (DO = <i>mucho/poco/ ...</i>)	37,3%	56	<i>De esto sé mucho / poco / nada...</i>
Relative Pro (DO = <i>lo que</i>)	8,0%	12	<i>... lo que pienso/sé/opino sobre eso</i>
Clause	2,7%	4	<i>Sobre eso pienso que ...</i>
Other	3,3%	5	
TOTAL	100%	150	

In addition to interrogatives, the construction is very common with a quantifier as object, as in (20). Here, the most frequent cases are the negative clauses with the verb *saber* and a negative quantifier as direct object, as in (21). The oblique complement delimits the dominion within which the negation or quantification is valid.

- (20) *¡mira! de fútbol sé bastante... aunque parezca mentira* (MADRID: 78)
 ‘look! about football, I know enough.... strange though it may seem’
- (21) *-¿Qué hay de Finita? ¿Nada? -De Finita no sé absolutamente nada.* (BAIRES: 428)
 ‘What’s about Finita? Nothing? – About Finita, I don’t know absolutely nothing’

Then, the oblique complement appears as a necessary reference point providing a dominion for an underspecified propositional content. The ‘complex transitive construction’ very rarely includes an explicit comple-

tive clause, as in (22). In that case, the oblique complement establishes the topic of the completive clause, or the topic of the ongoing discourse that develop the question word, as in (23), and it tends to coincide with the subject

- (22) ... *objetos de los que pensamos que se atraen entre sí* (LING:126)
 ‘...objects about which we think that they attract each other’
- (23) — *¿Qué piensas tú de los toros y el turismo?* — *Pienso que los toros ..., bueno, mejor dicho, el turismo ha dado un gran impulso a la fiesta nacional* (MAD: 92)
 ‘What do you think about bulls and tourism? -- I think that bulls..., well, rather, tourism has given a great impulse to bullfighting’

Nevertheless, the relevant factor is topicality. In (24), *la Feria* is the topic of the complement clause, but not the subject of *suprimir*

- (24) *Bueno, yo opino sobre la Feria que si estuviera en mis manos la suprimía.* (SEVILLA: 265)
 ‘Well, I have the opinion about the Fair that if it were in my hands I’ll suppress it’

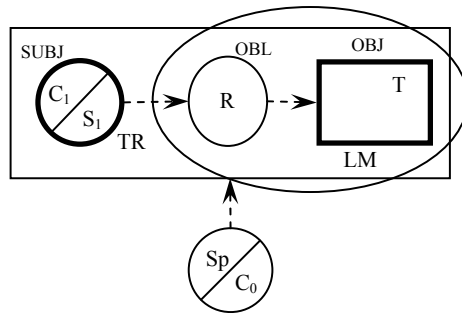

Figure 9. Oblique complement as a reference point

As stated by Langacker (2000: 26), topics are particular cases of reference point phenomena, representing things that give access to a proposition. In the oblique transitive construction, cognizer and propositional content continue to be trajector and landmark of the profiled relationship, as in figure 2, but the proposition content must be searched within the dominion of the oblique complement, which represents a reference-point established as discourse topic. The noteworthy point about this con-

struction is that the propositional content is frequently reduced to a question word or a quantifier, so a reference dominion is almost all we can get.

7. Conclusions

The meaning of cognition verbs involves a conceptualizer (typically, the subject) conceiving or assessing an event, typically represented by a complement clause in the object syntactic slot (*creo que es capaz de hacerlo*). Alternatively, many cognition verbs allow constructions with nominal object and adjectival predicative complement (*lo creo capaz de hacerlo*). It is well established (Rodríguez Espiñeira 2002) that there is no equivalence between these two syntactic schemas, and that subject-“raising” to object is motivated as a metonymical reference-point to the conceptualized event (Langacker 1993, 1995). Besides those two constructions, there is also some other constructions involving different configurations of reference-point and target: the schema SUB-DO-IO (*le recordé que era lunes, no le creo nada*), extended from the model of transfer verbs, and where an indirect object constitutes a reference-point for a nominal in its conceptual domain; and the schema SUB-DO-Oblique(*de*) (*¿Qué piensas tú de ella?*) where the prepositional adjunct represents a reference-point established as discourse topic.

Each construction proposes a specific construal of the scene, but the more relevant differences have to do with the relative prominence of entities that can serve as reference-point in the mental access path from a cognizer to a propositional content or assessment. Altogether, we hope to have shown how the notion of reference-point together with the frame-semantics associated with the verb can provide a unified account of cognition verb constructions in Spanish, which should be compatible with the syntactic and semantic differences (in profiling and salience) observed in syntactic constructions.

References

- Achard, Michel
1998 *Representation of Cognitive Structures. Syntax and Semantics of French Sentential Complements*. Berlin: Mouton de Gruyter.
- Delbecque, Nicole
2000 Cognitive constraints on complement clause cliticization in Spanish. In: K. Horie (ed.), *Complementation*, 149-198. Amsterdam: John Benjamins.

- Fauconnier, Gilles
1995 *Mental Spaces*. Cambridge: Cambridge University Press (2nd edition)
- Fauconnier, Gilles
1997 *Mappings in Thought and Language*. Cambridge: Cambridge University Press.
- Fauconnier, Gilles
1998 Mental spaces, language modalities, and conceptual integration. In: M. Tomasello (ed.), *The New Psychology of Language. Cognitive and Functional Approaches to Language Structure*, 251-280. Mahwah: Lawrence Erlbaum.
- Halliday, M.A.K.
1985 *An Introduction to Functional Grammar*. London: Arnold.
- Goldberg, Adele E.
1995 *Constructions. A Construction Grammar Approach to Argument Structure*. Chicago: University of Chicago Press.
- Kemmer, Suzanne and Arie Verhagen
1994 The grammar of causatives and the conceptual structure of events. *Cognitive Linguistics* 5: 115-156.
- Langacker, Ronald W.
1991 *Foundations of Cognitive Grammar. Volume 2: Descriptive application*. Stanford: Stanford University Press.
- Langacker, Ronald W.
1993 Reference-point constructions. *Cognitive Linguistics* 4: 1-38.
- Langacker, Ronald W.
1995 Raising and transparency. *Language* 71: 1-62.
- Langacker, Ronald W.
2000 Topic, subject, and possessor. In: H. G. Simonsen & R. T. Endresen (eds.), *A Cognitive Approach to the Verb. Morphological and Constructional Perspectives*, 11-48. Berlin: Mouton de Gruyter.
- Maldonado, Ricardo
2002 Objective and Subjective Datives. *Cognitive Linguistics* 13/1: 1-65.
- Postal, Paul M.
1974 *On Raising: One Rule of English Grammar and Its Theoretical Implications*. Cambridge: The MIT Press.
- Rodríguez Espiñeira, María José
2002 Alternancias de esquema sintáctico con predicados de valoración intelectual. In: A. Veiga, M. González e M. Souto (eds.) *Léxico y Gramática*, 313-326. Lugo: Tris Tram.